

CATALOGO
2022



nice

EMERGENCY LIGHTING

VOLUME 5



MADE IN ITALY

contact us:

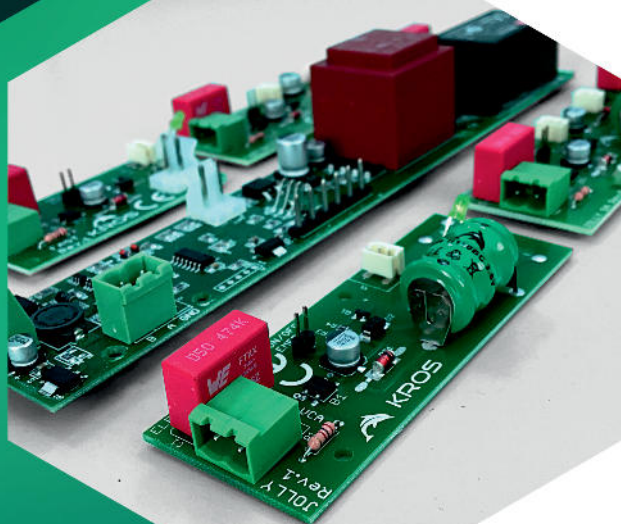

QUALITY
 MAKES THE
 DIFFERENCE

MARCATURA CE

Attesta la conformità dei prodotti alle direttive della Comunità Europea: LV/73/23/CEE - 93/68/CEE - 2006/95 CE EMC 89/336/CEE - 92/31/CEE - 93/68/CEE - 2004/108/CE.

SISTEMA DI QUALITÀ ISO 9001

È un importante riconoscimento della qualità dei processi aziendali, che consente ai clienti di avere la più assoluta fiducia nei confronti dell'azienda Elettronica Kros.

9001:2015

ELETTRONICA KROS S.R.L.

è un'azienda italiana specializzata nella realizzazione di sistemi per l'installazione elettrica. Dal 1980 progetta e produce al suo interno apparecchiature elettriche ed elettroniche dedicate ai settori dell'impiantistica civile ed industriale, tutto ciò nel rispetto dell'autentico Made in Italy. Affidabilità, capacità, innovazione sono le motivazioni che rendono la nostra azienda un partner sicuro per chiunque desideri prodotti efficienti e competitivi.

Electronica Kros Srl is an Italian Company specialized in the implementation of electric installation systems. Since 1980 We have been designing and manufacturing electrical and electronic equipments dedicated to residential and industrial installation industries. All respecting the authentic Made In Italy. Reliability, skill and innovation are the reasons why our Company is the ideal partner for anyone willing efficient and competitive products.

- **Engineering**
- **Prototipazione**
- **Realizzazione piccola serie**
- **Industrializzazione del prodotto**

*Engineering
 Prototyping
 Mini-series implementation
 Mass production*

Elettronica Kros si rivolge ai seguenti clienti:
Elettronica Kros' target customers are:

- **OEM** / OEM
- **Distributori** / Distributors
- **Installatori** / Installers
- **Progettisti** / Designers
- **Enti** / Organizations
- **Grandi impianti** / Large installations

PRODUZIONE 100% ITALIANA

La nostra caratteristica è quella di progettare e produrre totalmente MADE IN ITALY. Siamo in grado di progettare, disegnare, prototipare, costruire ed industrializzare qualsiasi prodotto elettronico che occorra. La capacità progettuale, sia elettronica che meccanica, inserisce Elettronica Kros nel gradino massimo di interesse di ogni azienda che vuole inserire nella propria gamma di prodotti: articoli esclusivi, affidabili ed allo stesso tempo competitivi. La nostra struttura è in grado di soddisfare richieste per piccoli, medi e grandi lotti di prodotto.

Our feature is designing and manufacturing totally MADE IN ITALY products. We can design, draw, prototype, build and industrialize any electronic product that is needed. Design ability, both electronic and mechanical, inserts Elettronica Kros in the highest level of interest of every company willing to include in its product range: exclusive, reliable and at the same time competitive items. Our facility is able to satisfy requests for small, medium and large batches of product.

GUIDA ALLE DIVERSE SERIE DI LAMPADRE DI EMERGENZA

Abbiamo una risposta per ogni tua esigenza, la vasta gamma garantisce una soluzione anche per le richieste fuori dall'ordinario. Il riepilogo sottostante permette di avere una panoramica sulle 7 serie di lampade ingegnerizzate e prodotte con orgoglio dalla Elettronica Kros, totalmente in Italia.

STANDARD

Le lampade di emergenza STANDARD sono apparecchi autonomi alimentati a 230V. Sono equipaggiate con una batteria al Ni-Mh che consente, in caso di mancanza di corrente, alle versioni S.E. di accendersi e a quelle S.A. di rimanere accese, garantendo quindi come da normativa un'illuminazione di emergenza e salvaguardando la sicurezza e l'incolumità delle persone.

• EN 61547 • EN 1838 • EN 60598-2-22 • EN 62471 • EN 55015, Classe B • EN 60598-1 • EN 61347-2-7

AUTOTESTING

Le lampade di emergenza della serie AUTOTESTING hanno come caratteristica principale quella di eseguire autonomamente un test funzionale di autodiagnosi ogni 15 gg con accensione della barra LED per circa 20 secondi. Il test di autonomia della batteria, invece, viene eseguito autonomamente ogni 84 gg con il raggiungimento di scarica completa per verificare la durata effettiva dell'autonomia specificata dal modello di lampada. Comunicano il loro stato tramite il colore ed il lampeggio del LED. Su richiesta è possibile personalizzare l'intervallo di tempo tra un test e l'altro.

Schema guida del comportamento del LED di segnalazione:

COMPORTAMENTO LED DI SEGNALAZIONE	
●	Lampeggiante (test inibiti)
●	Lampeggiante (test in corso)
●	Luce fissa (apparecchio funzionante)
●	Lampeggiante (test accensione lampada fallito)
●	Luce fissa (test durata batteria fallito)
● ●	Lampeggio sequenziale (batteria non collegata)
○	Spento (rete assente)

• EN 61547 • EN 1838 • EN 60598-2-22 • EN 62471 • EN 55015, Classe B • EN 60598-1 • EN 61347-2-7 • EN 62034

CENTRAL SYSTEM

Il CENTRAL SYSTEM è un sistema di illuminazione di emergenza centralizzato, che permette di gestire e controllare l'impianto sul posto o da remoto; questo grazie alle centrali che ogni 24 ore monitorano ogni singola lampada offrendo inoltre la possibilità di stampare report certificati che testimoniano l'esito della diagnosi. La gestione di ogni sistema si effettua tramite PC, collegandolo alla centrale, o da remoto tramite indirizzo IP web server. Per questi sistemi si utilizzano le relative lampade della serie CENTRAL SYSTEM, munite di pacco batteria a bordo ed alimentate a 230V. Conforme alla normativa CEI EN 62034.

• EN 61547 • EN 1838 • EN 60598-2-22 • EN 62471 • EN 55015, Classe B • EN 60598-1 • EN 61347-2-7 • EN 62034

S.O.S. GROUND

Il sistema UPS centralizzato S.O.S.GROUND ha le stesse caratteristiche del CENTRAL SYSTEM con la differenza che la centrale stessa alimenta le lampade dell'impianto grazie ad un pacco batteria separato dalla centrale. Per questi sistemi si utilizzano le relative lampade della serie S.O.S. GROUND, prive di pacco batteria a bordo ed alimentate a 230V dalla centrale. Conforme alla normativa CEI EN 62034.

• EN 61547 • EN 1838 • EN 60598-2-22 • EN 62471 • EN 55015, Classe B • EN 60598-1 • EN 61347-2-7 • EN 62034

S.O.S. SYSTEM 24V

Il sistema UPS centralizzato S.O.S. SYSTEM 24V ha le stesse caratteristiche del S.O.S. GROUND con la differenza che la centrale alimenta le lampade dell'impianto a 24V. Per questi sistemi si utilizzano le relative lampade della serie S.O.S. SYSTEM 24V, prive di pacco batteria a bordo ed alimentate a 24V dalla centrale. Conforme alla normativa CEI EN 62034.

• EN 61547 • EN 1838 • EN 60598-2-22 • EN 62471 • EN 55015, Classe B • EN 60598-1 • EN 61347-2-7 • EN 62034

S.O.S. SYSTEM 48V

Il sistema UPS centralizzato S.O.S. SYSTEM 48V ha le stesse caratteristiche del S.O.S. GROUND con la differenza che la centrale alimenta le lampade dell'impianto a 48V. Per questi sistemi si utilizzano le relative lampade della serie S.O.S. SYSTEM 48V, prive di pacco batteria a bordo ed alimentate a 48V dalla centrale. Conforme alla normativa CEI EN 62034.

• EN 61547 • EN 1838 • EN 60598-2-22 • EN 62471 • EN 55015, Classe B • EN 60598-1 • EN 61347-2-7 • EN 62034

SOLOLUCE

Le lampade della serie SOLOLUCE non dispongono di pacco batteria a bordo, possono quindi essere gestite da centrali UPS S.O.S. o essere semplicemente alimentate a 230V ed essere utilizzate per illuminazione ordinaria. Disponibili anche in bassa tensione 12V.

• EN 61547 • EN 1838 • EN 60598-2-22 • EN 62471 • EN 55015, Classe B • EN 60598-1 • EN 61347-2-7

INDICE



nice

1



nice

EKO

9



ACCESSORI

nice

14



IDEALE PER INSTALLAZIONI IN AMBIENTI COME:

- UFFICI
- ABITAZIONI PRIVATE
- NEGOZI
- ALBERGHI

CARATTERISTICHE PRINCIPALI:



Dimensioni compatte



Ampia gamma
da 75 a 500 lumen



Adatta per interni ed
esterni (IP42 o IP65)



LAMPADA DI EMERGENZA A LED

Fabbricazione elettronica italiana al 100%
100% Italian electronics manufacturing

Alimentazione 230Vca -50Hz
230Vca -50Hz input Power

Grado di protezione IP42 o IP65
IP42 or IP65 protection degree

Grado di resistenza agli urti IK07
IK07 shock resistance degree

Materiale corpo in policarbonato autoestinguente V2
Self-extinguishing (V2) polycarbonate body material

Materiale diffusore in policarbonato autoestinguente V2
Self-extinguishing (V2) polycarbonate reflector material

Temperatura operativa 0°C / +40°C
0°C / +40°C working temperature

Glow wire test 850°C (2.0mm)
850°C (2.0mm) glow wire test

Tipo di funzionamento S.E. o S.E./S.A.
NOT PERMANENT or PERMANENT functioning

Autonomia da 60 a 180 minuti
From 60 to 180 minutes autonomy

Tempo di ricarica 12 ore o 24 ore
12 or 24 hours recharging time

Montaggio a parete
Wall mounting

Batteria Ni-MH ricaricabile, garantita 24 mesi
Rechargeable Ni-MH battery, 24 months warranty

Ricarica della batteria a corrente costante
Battery recharging at constant rated current

Protezione della batteria a scarica completa
Battery protection at full discharging

LED verde spia presenza rete
Green LED power ON

Fonte luminosa LED Alta efficienza
LED High efficiency Light source

Gamma flusso luminoso nominale da 75 a 500 Lumen
Luminous flux range from 75 to 500 Lumen

Resa cromatica (CRI) 80
80 colour rendering index

Temperatura colore 5000K
5000K colour temperature

Rischio fotobiologico ZERO secondo EN62471
Photobiological NO-risk according to EN62471

Garanzia sulla fonte luminosa LED di 10 anni
10 years warranty on LED light source

Conforme alle normative vigenti:
Complies with current Standards:

- EN 61547 • EN 1838 • EN 60598-2-22 • EN 62471 • EN 55015, Classe B
- EN 60598-1 • EN 61347-2-7 • EN 62034 (Autotesting Version)



- REST MODE
- POSSIBILITÀ DI INIBIZIONE

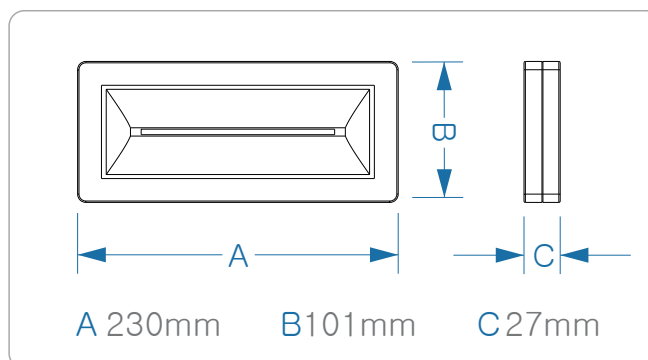
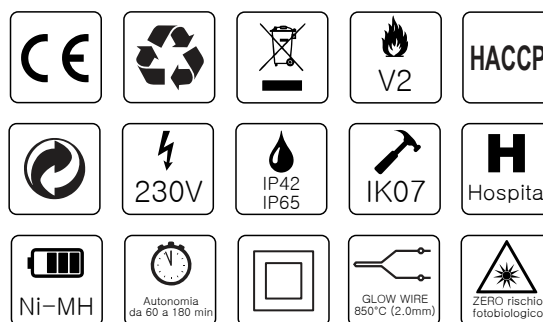

Le lampade IP65 vengono fornite con la guarnizione in silicone espanso già inserita + il raccordo tubo-lampada d. 16mm

IP65 lamps are supplied with the foam silicone gasket (already inserted) + tube-lamp junction d. 16mm

Diagramma polare
Polar diagram

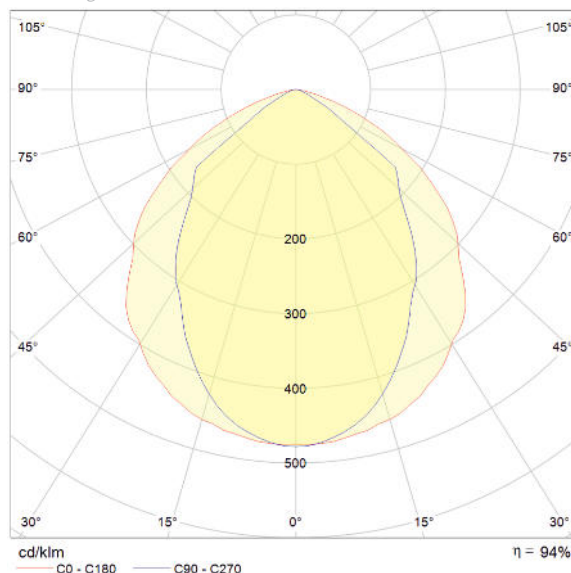

NICE - STANDARD S.E. IP42 - RICARICA 12H							
CODICE	ARTICOLO	LUMEN S.E.		AUTONOMIA	BATTERIA	TEMPO DI RICARICA	MODO
59371	NICE75NM10SE42	75		60 min	Ni-MH	12 h	S.E.
59372	NICE75NM15SE42	75		90 min	Ni-MH	12 h	S.E.
59373	NICE75NM20SE42	75		120 min	Ni-MH	12 h	S.E.
59374	NICE75NM30SE42	75		180 min	Ni-MH	12 h	S.E.
59375	NICE90NM10SE42	90		60 min	Ni-MH	12 h	S.E.
59376	NICE90NM15SE42	90		90 min	Ni-MH	12 h	S.E.
59377	NICE90NM20SE42	90		120 min	Ni-MH	12 h	S.E.
59378	NICE90NM30SE42	90		180 min	Ni-MH	12 h	S.E.
59379	NICE115NM10SE42	115		60 min	Ni-MH	12 h	S.E.
59380	NICE115NM15SE42	115		90 min	Ni-MH	12 h	S.E.
59381	NICE115NM20SE42	115		120 min	Ni-MH	12 h	S.E.
59382	NICE115NM30SE42	115		180 min	Ni-MH	12 h	S.E.
59383	NICE150NM10SE42	150		60 min	Ni-MH	12 h	S.E.
59384	NICE150NM15SE42	150		90 min	Ni-MH	12 h	S.E.
59385	NICE150NM20SE42	150		120 min	Ni-MH	12 h	S.E.
59386	NICE150NM30SE42	150		180 min	Ni-MH	12 h	S.E.
59387	NICE200NM10SE42	200		60 min	Ni-MH	12 h	S.E.
59388	NICE200NM15SE42	200		90 min	Ni-MH	12 h	S.E.
59389	NICE200NM20SE42	200		120 min	Ni-MH	12 h	S.E.
59390	NICE200NM30SE42	200		180 min	Ni-MH	12 h	S.E.
59391	NICE230NM10SE42	230		60 min	Ni-MH	12 h	S.E.
59392	NICE230NM15SE42	230		90 min	Ni-MH	12 h	S.E.
59393	NICE230NM20SE42	230		120 min	Ni-MH	12 h	S.E.
59394	NICE300NM10SE42	300		60 min	Ni-MH	12 h	S.E.
59395	NICE300NM15SE42	300		90 min	Ni-MH	12 h	S.E.
59396	NICE300NM20SE42	300		120 min	Ni-MH	12 h	S.E.
59397	NICE380NM10SE42	380		60 min	Ni-MH	12 h	S.E.
59398	NICE380NM15SE42	380		90 min	Ni-MH	12 h	S.E.
60688	NICE500NM10SE42	500		60 min	Ni-MH	12 h	S.E.

NICE - STANDARD S.E./S.A. IP42 - RICARICA 12H							
CODICE	ARTICOLO	LUMEN S.E.	LUMEN S.A.	AUTONOMIA	BATTERIA	TEMPO DI RICARICA	MODO
59399	NICE75NM10SESA42	75	75	60 min	Ni-MH	12 h	S.E./S.A.
59400	NICE75NM15SESA42	75	75	90 min	Ni-MH	12 h	S.E./S.A.
59401	NICE75NM20SESA42	75	75	120 min	Ni-MH	12 h	S.E./S.A.
59402	NICE75NM30SESA42	75	75	180 min	Ni-MH	12 h	S.E./S.A.
59403	NICE90NM10SESA42	90	90	60 min	Ni-MH	12 h	S.E./S.A.
59404	NICE90NM15SESA42	90	90	90 min	Ni-MH	12 h	S.E./S.A.
59405	NICE90NM20SESA42	90	90	120 min	Ni-MH	12 h	S.E./S.A.
59406	NICE90NM30SESA42	90	90	180 min	Ni-MH	12 h	S.E./S.A.
59407	NICE115NM10SESA42	115	115	60 min	Ni-MH	12 h	S.E./S.A.
59408	NICE115NM15SESA42	115	115	90 min	Ni-MH	12 h	S.E./S.A.
59409	NICE115NM20SESA42	115	115	120 min	Ni-MH	12 h	S.E./S.A.
59410	NICE115NM30SESA42	115	100	180 min	Ni-MH	12 h	S.E./S.A.
59411	NICE150NM10SESA42	150	150	60 min	Ni-MH	12 h	S.E./S.A.
59412	NICE150NM15SESA42	150	150	90 min	Ni-MH	12 h	S.E./S.A.
59413	NICE150NM20SESA42	150	100	120 min	Ni-MH	12 h	S.E./S.A.
59414	NICE200NM10SESA42	200	150	60 min	Ni-MH	12 h	S.E./S.A.
59415	NICE200NM15SESA42	200	100	90 min	Ni-MH	12 h	S.E./S.A.
59416	NICE200NM20SESA42	200	100	120 min	Ni-MH	12 h	S.E./S.A.
59417	NICE230NM10SESA42	230	150	60 min	Ni-MH	12 h	S.E./S.A.
59418	NICE230NM15SESA42	230	100	90 min	Ni-MH	12 h	S.E./S.A.
59419	NICE300NM10SESA42	300	100	60 min	Ni-MH	12 h	S.E./S.A.
59420	NICE380NM10SESA42	380	100	60 min	Ni-MH	12 h	S.E./S.A.

NICE - STANDARD S.E./S.A. IP42 - RICARICA 24H							
CODICE	ARTICOLO	LUMEN S.E.	LUMEN S.A.	AUTONOMIA	BATTERIA	TEMPO DI RICARICA	MODO
59421	NICE75NM10SESA42-24H	75	75	60 min	Ni-MH	24 h	S.E./S.A.
59422	NICE75NM15SESA42-24H	75	75	90 min	Ni-MH	24 h	S.E./S.A.
59423	NICE75NM20SESA42-24H	75	75	120 min	Ni-MH	24 h	S.E./S.A.
59424	NICE75NM30SESA42-24H	75	75	180 min	Ni-MH	24 h	S.E./S.A.
59425	NICE90NM10SESA42-24H	90	90	60 min	Ni-MH	24 h	S.E./S.A.
59426	NICE90NM15SESA42-24H	90	90	90 min	Ni-MH	24 h	S.E./S.A.
59427	NICE90NM20SESA42-24H	90	90	120 min	Ni-MH	24 h	S.E./S.A.
59428	NICE90NM30SESA42-24H	90	90	180 min	Ni-MH	24 h	S.E./S.A.
59429	NICE115NM10SESA42-24H	115	115	60 min	Ni-MH	24 h	S.E./S.A.
59430	NICE115NM15SESA42-24H	115	115	90 min	Ni-MH	24 h	S.E./S.A.
59431	NICE115NM20SESA42-24H	115	115	120 min	Ni-MH	24 h	S.E./S.A.
59432	NICE115NM30SESA42-24H	115	115	180 min	Ni-MH	24 h	S.E./S.A.
59433	NICE150NM10SESA42-24H	150	150	60 min	Ni-MH	24 h	S.E./S.A.
59434	NICE150NM15SESA42-24H	150	150	90 min	Ni-MH	24 h	S.E./S.A.
59435	NICE150NM20SESA42-24H	150	150	120 min	Ni-MH	24 h	S.E./S.A.
59436	NICE150NM30SESA42-24H	150	120	180 min	Ni-MH	24 h	S.E./S.A.
59437	NICE200NM10SESA42-24H	200	180	60 min	Ni-MH	24 h	S.E./S.A.
59438	NICE200NM15SESA42-24H	200	160	90 min	Ni-MH	24 h	S.E./S.A.
59439	NICE200NM20SESA42-24H	200	160	120 min	Ni-MH	24 h	S.E./S.A.
59440	NICE200NM30SESA42-24H	200	120	180 min	Ni-MH	24 h	S.E./S.A.
59441	NICE230NM10SESA42-24H	230	180	60 min	Ni-MH	24 h	S.E./S.A.
59442	NICE230NM15SESA42-24H	230	160	90 min	Ni-MH	24 h	S.E./S.A.

59443	NICE230NM20SESA42-24H	230	120	120 min	Ni-MH	24 h	S.E./S.A.
59444	NICE300NM10SESA42-24H	300	160	60 min	Ni-MH	24 h	S.E./S.A.
59445	NICE300NM15SESA42-24H	300	120	90 min	Ni-MH	24 h	S.E./S.A.
59446	NICE300NM20SESA42-24H	300	120	120 min	Ni-MH	24 h	S.E./S.A.
59447	NICE380NM10SESA42-24H	380	160	60 min	Ni-MH	24 h	S.E./S.A.
59448	NICE380NM15SESA42-24H	380	120	90 min	Ni-MH	24 h	S.E./S.A.

NICE - STANDARD S.E. IP65 - RICARICA 12H

CODICE	ARTICOLO	LUMEN S.E.		AUTONOMIA	BATTERIA	TEMPO DI RICARICA	MODO
59449	NICE75NM10SE65	75		60 min	Ni-MH	12 h	S.E.
59450	NICE75NM15SE65	75		90 min	Ni-MH	12 h	S.E.
59451	NICE75NM20SE65	75		120 min	Ni-MH	12 h	S.E.
59452	NICE75NM30SE65	75		180 min	Ni-MH	12 h	S.E.
59453	NICE90NM10SE65	90		60 min	Ni-MH	12 h	S.E.
59454	NICE90NM15SE65	90		90 min	Ni-MH	12 h	S.E.
59455	NICE90NM20SE65	90		120 min	Ni-MH	12 h	S.E.
59456	NICE90NM30SE65	90		180 min	Ni-MH	12 h	S.E.
59457	NICE115NM10SE65	115		60 min	Ni-MH	12 h	S.E.
59458	NICE115NM15SE65	115		90 min	Ni-MH	12 h	S.E.
59459	NICE115NM20SE65	115		120 min	Ni-MH	12 h	S.E.
59460	NICE115NM30SE65	115		180 min	Ni-MH	12 h	S.E.
59461	NICE150NM10SE65	150		60 min	Ni-MH	12 h	S.E.
59462	NICE150NM15SE65	150		90 min	Ni-MH	12 h	S.E.
59463	NICE150NM20SE65	150		120 min	Ni-MH	12 h	S.E.
59464	NICE150NM30SE65	150		180 min	Ni-MH	12 h	S.E.
59465	NICE200NM10SE65	200		60 min	Ni-MH	12 h	S.E.
59466	NICE200NM15SE65	200		90 min	Ni-MH	12 h	S.E.
59467	NICE200NM20SE65	200		120 min	Ni-MH	12 h	S.E.
59468	NICE200NM30SE65	200		180 min	Ni-MH	12 h	S.E.
59469	NICE230NM10SE65	230		60 min	Ni-MH	12 h	S.E.
59470	NICE230NM15SE65	230		90 min	Ni-MH	12 h	S.E.
59471	NICE230NM20SE65	230		120 min	Ni-MH	12 h	S.E.
59472	NICE300NM10SE65	300		60 min	Ni-MH	12 h	S.E.
59473	NICE300NM15SE65	300		90 min	Ni-MH	12 h	S.E.
59474	NICE300NM20SE65	300		120 min	Ni-MH	12 h	S.E.
59475	NICE380NM10SE65	380		60 min	Ni-MH	12 h	S.E.
59476	NICE380NM15SE65	380		90 min	Ni-MH	12 h	S.E.
60689	NICE500NM10SE65	500		60 min	Ni-MH	12 h	S.E.

NICE - STANDARD S.E./S.A. IP65 - RICARICA 12H

CODICE	ARTICOLO	LUMEN S.E.	LUMEN S.A.	AUTONOMIA	BATTERIA	TEMPO DI RICARICA	MODO
59477	NICE75NM10SESA65	75	75	60 min	Ni-MH	12 h	S.E./S.A.
59478	NICE75NM15SESA65	75	75	90 min	Ni-MH	12 h	S.E./S.A.
59479	NICE75NM20SESA65	75	75	120 min	Ni-MH	12 h	S.E./S.A.
59480	NICE75NM30SESA65	75	75	180 min	Ni-MH	12 h	S.E./S.A.
59481	NICE90NM10SESA65	90	90	60 min	Ni-MH	12 h	S.E./S.A.
59482	NICE90NM15SESA65	90	90	90 min	Ni-MH	12 h	S.E./S.A.
59483	NICE90NM20SESA65	90	90	120 min	Ni-MH	12 h	S.E./S.A.
59484	NICE90NM30SESA65	90	90	180 min	Ni-MH	12 h	S.E./S.A.
59485	NICE115NM10SESA65	115	115	60 min	Ni-MH	12 h	S.E./S.A.
59486	NICE115NM15SESA65	115	115	90 min	Ni-MH	12 h	S.E./S.A.
59487	NICE115NM20SESA65	115	115	120 min	Ni-MH	12 h	S.E./S.A.
59488	NICE115NM30SESA65	115	100	180 min	Ni-MH	12 h	S.E./S.A.
59489	NICE150NM10SESA65	150	150	60 min	Ni-MH	12 h	S.E./S.A.
59490	NICE150NM15SESA65	150	150	90 min	Ni-MH	12 h	S.E./S.A.
59491	NICE150NM20SESA65	150	100	120 min	Ni-MH	12 h	S.E./S.A.
59492	NICE200NM10SESA65	200	150	60 min	Ni-MH	12 h	S.E./S.A.
59493	NICE200NM15SESA65	200	100	90 min	Ni-MH	12 h	S.E./S.A.
59494	NICE200NM20SESA65	200	100	120 min	Ni-MH	12 h	S.E./S.A.
59495	NICE230NM10SESA65	230	150	60 min	Ni-MH	12 h	S.E./S.A.
59496	NICE230NM15SESA65	230	100	90 min	Ni-MH	12 h	S.E./S.A.
59497	NICE300NM10SESA65	300	100	60 min	Ni-MH	12 h	S.E./S.A.
59498	NICE380NM10SESA65	380	100	60 min	Ni-MH	12 h	S.E./S.A.

NICE - STANDARD S.E./S.A. IP65 - RICARICA 24H

CODICE	ARTICOLO	LUMEN S.E.	LUMEN S.A.	AUTONOMIA	BATTERIA	TEMPO DI RICARICA	MODO
59499	NICE75NM10SESA65-24H	75	75	60 min	Ni-MH	24 h	S.E./S.A.
59500	NICE75NM15SESA65-24H	75	75	90 min	Ni-MH	24 h	S.E./S.A.
59501	NICE75NM20SESA65-24H	75	75	120 min	Ni-MH	24 h	S.E./S.A.
59502	NICE75NM30SESA65-24H	75	75	180 min	Ni-MH	24 h	S.E./S.A.
59503	NICE90NM10SESA65-24H	90	90	60 min	Ni-MH	24 h	S.E./S.A.
59504	NICE90NM15SESA65-24H	90	90	90 min	Ni-MH	24 h	S.E./S.A.
59505	NICE90NM20SESA65-24H	90	90	120 min	Ni-MH	24 h	S.E./S.A.
59506	NICE90NM30SESA65-24H	90	90	180 min	Ni-MH	24 h	S.E./S.A.
59507	NICE115NM10SESA65-24H	115	115	60 min	Ni-MH	24 h	S.E./S.A.
59508	NICE115NM15SESA65-24H	115	115	90 min	Ni-MH	24 h	S.E./S.A.
59509	NICE115NM20SESA65-24H	115	115	120 min	Ni-MH	24 h	S.E./S.A.
59510	NICE115NM30SESA65-24H	115	115	180 min	Ni-MH	24 h	S.E./S.A.
59511	NICE150NM10SESA65-24H	150	150	60 min	Ni-MH	24 h	S.E./S.A.
59512	NICE150NM15SESA65-24H	150	150	90 min	Ni-MH	24 h	S.E./S.A.
59513	NICE150NM20SESA65-24H	150	150	120 min	Ni-MH	24 h	S.E./S.A.
59514	NICE150NM30SESA65-24H	150	120	180 min	Ni-MH	24 h	S.E./S.A.



Ricarica



24 ore

59515	NICE200NM10SESA65-24H	200	180	60 min	Ni-MH	24 h	S.E./S.A.
59516	NICE200NM15SESA65-24H	200	160	90 min	Ni-MH	24 h	S.E./S.A.
59517	NICE200NM20SESA65-24H	200	160	120 min	Ni-MH	24 h	S.E./S.A.
59518	NICE200NM30SESA65-24H	200	120	180 min	Ni-MH	24 h	S.E./S.A.
59519	NICE230NM10SESA65-24H	230	180	60 min	Ni-MH	24 h	S.E./S.A.
59520	NICE230NM15SESA65-24H	230	160	90 min	Ni-MH	24 h	S.E./S.A.
59521	NICE230NM20SESA65-24H	230	120	120 min	Ni-MH	24 h	S.E./S.A.
59522	NICE300NM10SESA65-24H	300	160	60 min	Ni-MH	24 h	S.E./S.A.
59523	NICE300NM15SESA65-24H	300	120	90 min	Ni-MH	24 h	S.E./S.A.
59524	NICE300NM20SESA65-24H	300	120	120 min	Ni-MH	24 h	S.E./S.A.
59525	NICE380NM10SESA65-24H	380	160	60 min	Ni-MH	24 h	S.E./S.A.
59526	NICE380NM15SESA65-24H	380	120	90 min	Ni-MH	24 h	S.E./S.A.

NICE - AUTOTESTING S.E. IP42

CODICE	ARTICOLO	LUMEN S.E.	AUTONOMIA	BATTERIA	TEMPO DI RICARICA	MODO
60691	NICE-AT-100NM10SE42	100	60 min	Ni-MH	12 h	S.E.
60692	NICE-AT-100NM15SE42	100	90 min	Ni-MH	12 h	S.E.
60693	NICE-AT-100NM20SE42	100	120 min	Ni-MH	12 h	S.E.
60694	NICE-AT-100NM30SE42	100	180 min	Ni-MH	12 h	S.E.
60695	NICE-AT-150NM10SE42	150	60 min	Ni-MH	12 h	S.E.
60696	NICE-AT-150NM15SE42	150	90 min	Ni-MH	12 h	S.E.
60697	NICE-AT-150NM20SE42	150	120 min	Ni-MH	12 h	S.E.
60698	NICE-AT-150NM30SE42	150	180 min	Ni-MH	12 h	S.E.
60699	NICE-AT-200NM10SE42	200	60 min	Ni-MH	12 h	S.E.
60700	NICE-AT-200NM15SE42	200	90 min	Ni-MH	12 h	S.E.
60701	NICE-AT-200NM20SE42	200	120 min	Ni-MH	12 h	S.E.
60702	NICE-AT-250NM10SE42	250	60 min	Ni-MH	12 h	S.E.
60703	NICE-AT-250NM15SE42	250	90 min	Ni-MH	12 h	S.E.
60704	NICE-AT-250NM20SE42	250	120 min	Ni-MH	12 h	S.E.
60705	NICE-AT-300NM10SE42	300	60 min	Ni-MH	12 h	S.E.
60706	NICE-AT-300NM15SE42	300	90 min	Ni-MH	12 h	S.E.
60707	NICE-AT-300NM20SE42	300	120 min	Ni-MH	12 h	S.E.
60708	NICE-AT-400NM10SE42	400	60 min	Ni-MH	12 h	S.E.
60709	NICE-AT-400NM15SE42	400	90 min	Ni-MH	12 h	S.E.
60710	NICE-AT-500NM10SE42	500	60 min	Ni-MH	12 h	S.E.

NICE - AUTOTESTING S.E./S.A. IP42

CODICE	ARTICOLO	LUMEN S.E.	LUMEN S.A.	AUTONOMIA	BATTERIA	TEMPO DI RICARICA	MODO
60711	NICE-AT-100NM10SESA42	100	100	60 min	Ni-MH	12 h	S.E./S.A.
60712	NICE-AT-100NM15SESA42	100	100	90 min	Ni-MH	12 h	S.E./S.A.
60713	NICE-AT-100NM20SESA42	100	100	120 min	Ni-MH	12 h	S.E./S.A.
60714	NICE-AT-100NM30SESA42	100	100	180 min	Ni-MH	12 h	S.E./S.A.
60715	NICE-AT-150NM10SESA42	150	150	60 min	Ni-MH	12 h	S.E./S.A.
60716	NICE-AT-150NM15SESA42	150	150	90 min	Ni-MH	12 h	S.E./S.A.
60717	NICE-AT-150NM20SESA42	150	150	120 min	Ni-MH	12 h	S.E./S.A.
60718	NICE-AT-150NM30SESA42	150	150	180 min	Ni-MH	12 h	S.E./S.A.
60719	NICE-AT-200NM10SESA42	200	200	60 min	Ni-MH	12 h	S.E./S.A.
60720	NICE-AT-200NM15SESA42	200	200	90 min	Ni-MH	12 h	S.E./S.A.
60721	NICE-AT-200NM20SESA42	200	200	120 min	Ni-MH	12 h	S.E./S.A.
60722	NICE-AT-250NM10SESA42	250	250	60 min	Ni-MH	12 h	S.E./S.A.
60723	NICE-AT-250NM15SESA42	250	250	90 min	Ni-MH	12 h	S.E./S.A.
60724	NICE-AT-250NM20SESA42	250	250	120 min	Ni-MH	12 h	S.E./S.A.
60725	NICE-AT-300NM10SESA42	300	300	60 min	Ni-MH	12 h	S.E./S.A.
60726	NICE-AT-300NM15SESA42	300	300	90 min	Ni-MH	12 h	S.E./S.A.
60727	NICE-AT-300NM20SESA42	300	300	120 min	Ni-MH	12 h	S.E./S.A.
60728	NICE-AT-400NM10SESA42	400	400	60 min	Ni-MH	12 h	S.E./S.A.
60729	NICE-AT-400NM15SESA42	400	400	90 min	Ni-MH	12 h	S.E./S.A.
60730	NICE-AT-500NM10SESA42	500	500	60 min	Ni-MH	12 h	S.E./S.A.

NICE - AUTOTESTING S.E. IP65

CODICE	ARTICOLO	LUMEN S.E.	AUTONOMIA	BATTERIA	TEMPO DI RICARICA	MODO
60731	NICE-AT-100NM10SE65	100	60 min	Ni-MH	12 h	S.E.
60732	NICE-AT-100NM15SE65	100	90 min	Ni-MH	12 h	S.E.
60733	NICE-AT-100NM20SE65	100	120 min	Ni-MH	12 h	S.E.
60734	NICE-AT-100NM30SE65	100	180 min	Ni-MH	12 h	S.E.
60735	NICE-AT-150NM10SE65	150	60 min	Ni-MH	12 h	S.E.
60736	NICE-AT-150NM15SE65	150	90 min	Ni-MH	12 h	S.E.
60737	NICE-AT-150NM20SE65	150	120 min	Ni-MH	12 h	S.E.
60738	NICE-AT-150NM30SE65	150	180 min	Ni-MH	12 h	S.E.
60739	NICE-AT-200NM10SE65	200	60 min	Ni-MH	12 h	S.E.
60740	NICE-AT-200NM15SE65	200	90 min	Ni-MH	12 h	S.E.
60741	NICE-AT-200NM20SE65	200	120 min	Ni-MH	12 h	S.E.
60742	NICE-AT-250NM10SE65	250	60 min	Ni-MH	12 h	S.E.
60743	NICE-AT-250NM15SE65	250	90 min	Ni-MH	12 h	S.E.
60744	NICE-AT-250NM20SE65	250	120 min	Ni-MH	12 h	S.E.
60745	NICE-AT-300NM10SE65	300	60 min	Ni-MH	12 h	S.E.
60746	NICE-AT-300NM15SE65	300	90 min	Ni-MH	12 h	S.E.
60747	NICE-AT-300NM20SE65	300	120 min	Ni-MH	12 h	S.E.
60748	NICE-AT-400NM10SE65	400	60 min	Ni-MH	12 h	S.E.
60749	NICE-AT-400NM15SE65	400	90 min	Ni-MH	12 h	S.E.
60750	NICE-AT-500NM10SE65	500	60 min	Ni-MH	12 h	S.E.

NICE - AUTOTESTING S.E./S.A. IP65							
CODICE	ARTICOLO	LUMEN S.E.	LUMEN S.A.	AUTONOMIA	BATTERIA	TEMPO DI RICARICA	MODO
60751	NICE-AT-100NM10SESA65	100	100	60 min	Ni-MH	12 h	S.E./S.A.
60752	NICE-AT-100NM15SESA65	100	100	90 min	Ni-MH	12 h	S.E./S.A.
60753	NICE-AT-100NM20SESA65	100	100	120 min	Ni-MH	12 h	S.E./S.A.
60754	NICE-AT-100NM30SESA65	100	100	180 min	Ni-MH	12 h	S.E./S.A.
60755	NICE-AT-150NM10SESA65	150	150	60 min	Ni-MH	12 h	S.E./S.A.
60756	NICE-AT-150NM15SESA65	150	150	90 min	Ni-MH	12 h	S.E./S.A.
60757	NICE-AT-150NM20SESA65	150	150	120 min	Ni-MH	12 h	S.E./S.A.
60758	NICE-AT-150NM30SESA65	150	150	180 min	Ni-MH	12 h	S.E./S.A.
60759	NICE-AT-200NM10SESA65	200	200	60 min	Ni-MH	12 h	S.E./S.A.
60760	NICE-AT-200NM15SESA65	200	200	90 min	Ni-MH	12 h	S.E./S.A.
60761	NICE-AT-200NM20SESA65	200	200	120 min	Ni-MH	12 h	S.E./S.A.
60762	NICE-AT-250NM10SESA65	250	250	60 min	Ni-MH	12 h	S.E./S.A.
60763	NICE-AT-250NM15SESA65	250	250	90 min	Ni-MH	12 h	S.E./S.A.
60764	NICE-AT-250NM20SESA65	250	250	120 min	Ni-MH	12 h	S.E./S.A.
60765	NICE-AT-300NM10SESA65	300	300	60 min	Ni-MH	12 h	S.E./S.A.
60766	NICE-AT-300NM15SESA65	300	300	90 min	Ni-MH	12 h	S.E./S.A.
60767	NICE-AT-300NM20SESA65	300	300	120 min	Ni-MH	12 h	S.E./S.A.
60768	NICE-AT-400NM10SESA65	400	400	60 min	Ni-MH	12 h	S.E./S.A.
60769	NICE-AT-400NM15SESA65	400	400	90 min	Ni-MH	12 h	S.E./S.A.
60770	NICE-AT-500NM10SESA65	500	500	60 min	Ni-MH	12 h	S.E./S.A.

NICE - CENTRAL SYSTEM S.E. IP42							
CODICE	ARTICOLO	LUMEN S.E.	LUMEN S.A.	AUTONOMIA	BATTERIA	TEMPO DI RICARICA	MODO
60771	NICE-CS-100NM10SE42	100		60 min	Ni-MH	12 h	S.E.
60772	NICE-CS-100NM15SE42	100		90 min	Ni-MH	12 h	S.E.
60773	NICE-CS-100NM20SE42	100		120 min	Ni-MH	12 h	S.E.
60774	NICE-CS-100NM30SE42	100		180 min	Ni-MH	12 h	S.E.
60775	NICE-CS-150NM10SE42	150		60 min	Ni-MH	12 h	S.E.
60776	NICE-CS-150NM15SE42	150		90 min	Ni-MH	12 h	S.E.
60777	NICE-CS-150NM20SE42	150		120 min	Ni-MH	12 h	S.E.
60778	NICE-CS-150NM30SE42	150		180 min	Ni-MH	12 h	S.E.
60779	NICE-CS-200NM10SE42	200		60 min	Ni-MH	12 h	S.E.
60780	NICE-CS-200NM15SE42	200		90 min	Ni-MH	12 h	S.E.
60781	NICE-CS-200NM20SE42	200		120 min	Ni-MH	12 h	S.E.
60782	NICE-CS-250NM10SE42	250		60 min	Ni-MH	12 h	S.E.
60783	NICE-CS-250NM15SE42	250		90 min	Ni-MH	12 h	S.E.
60784	NICE-CS-250NM20SE42	250		120 min	Ni-MH	12 h	S.E.
60785	NICE-CS-300NM10SE42	300		60 min	Ni-MH	12 h	S.E.
60786	NICE-CS-300NM15SE42	300		90 min	Ni-MH	12 h	S.E.
60787	NICE-CS-300NM20SE42	300		120 min	Ni-MH	12 h	S.E.
60788	NICE-CS-400NM10SE42	400		60 min	Ni-MH	12 h	S.E.
60789	NICE-CS-400NM15SE42	400		90 min	Ni-MH	12 h	S.E.
60790	NICE-CS-500NM10SE42	500		60 min	Ni-MH	12 h	S.E.

NICE - CENTRAL SYSTEM S.E./S.A. IP42							
CODICE	ARTICOLO	LUMEN S.E.	LUMEN S.A.	AUTONOMIA	BATTERIA	TEMPO DI RICARICA	MODO
60791	NICE-CS-100NM10SESA42	100	100	60 min	Ni-MH	12 h	S.E./S.A.
60792	NICE-CS-100NM15SESA42	100	100	90 min	Ni-MH	12 h	S.E./S.A.
60793	NICE-CS-100NM20SESA42	100	100	120 min	Ni-MH	12 h	S.E./S.A.
60794	NICE-CS-100NM30SESA42	100	100	180 min	Ni-MH	12 h	S.E./S.A.
60795	NICE-CS-150NM10SESA42	150	150	60 min	Ni-MH	12 h	S.E./S.A.
60796	NICE-CS-150NM15SESA42	150	150	90 min	Ni-MH	12 h	S.E./S.A.
60797	NICE-CS-150NM20SESA42	150	150	120 min	Ni-MH	12 h	S.E./S.A.
60798	NICE-CS-150NM30SESA42	150	150	180 min	Ni-MH	12 h	S.E./S.A.
60799	NICE-CS-200NM10SESA42	200	200	60 min	Ni-MH	12 h	S.E./S.A.
60800	NICE-CS-200NM15SESA42	200	200	90 min	Ni-MH	12 h	S.E./S.A.
60801	NICE-CS-200NM20SESA42	200	200	120 min	Ni-MH	12 h	S.E./S.A.
60802	NICE-CS-250NM10SESA42	250	250	60 min	Ni-MH	12 h	S.E./S.A.
60803	NICE-CS-250NM15SESA42	250	250	90 min	Ni-MH	12 h	S.E./S.A.
60804	NICE-CS-250NM20SESA42	250	250	120 min	Ni-MH	12 h	S.E./S.A.
60805	NICE-CS-300NM10SESA42	300	300	60 min	Ni-MH	12 h	S.E./S.A.
60806	NICE-CS-300NM15SESA42	300	300	90 min	Ni-MH	12 h	S.E./S.A.
60807	NICE-CS-300NM20SESA42	300	300	120 min	Ni-MH	12 h	S.E./S.A.
60808	NICE-CS-400NM10SESA42	400	400	60 min	Ni-MH	12 h	S.E./S.A.
60809	NICE-CS-400NM15SESA42	400	400	90 min	Ni-MH	12 h	S.E./S.A.
60810	NICE-CS-500NM10SESA42	500	500	60 min	Ni-MH	12 h	S.E./S.A.

NICE - CENTRAL SYSTEM S.E. IP65							
CODICE	ARTICOLO	LUMEN S.E.	LUMEN S.A.	AUTONOMIA	BATTERIA	TEMPO DI RICARICA	MODO
60811	NICE-CS-100NM10SE65	100		60 min	Ni-MH	12 h	S.E.
60812	NICE-CS-100NM15SE65	100		90 min	Ni-MH	12 h	S.E.
60813	NICE-CS-100NM20SE65	100		120 min	Ni-MH	12 h	S.E.
60814	NICE-CS-100NM30SE65	100		180 min	Ni-MH	12 h	S.E.
60815	NICE-CS-150NM10SE65	150		60 min	Ni-MH	12 h	S.E.
60816	NICE-CS-150NM15SE65	150		90 min	Ni-MH	12 h	S.E.
60817	NICE-CS-150NM20SE65	150		120 min	Ni-MH	12 h	S.E.
60818	NICE-CS-150NM30SE65	150		180 min	Ni-MH	12 h	S.E.
60819	NICE-CS-200NM10SE65	200		60 min	Ni-MH	12 h	S.E.
60820	NICE-CS-200NM15SE65	200		90 min	Ni-MH	12 h	S.E.
60821	NICE-CS-200NM20SE65	200		120 min	Ni-MH	12 h	S.E.

60822	NICE-CS-250NM10SE65	250	60 min	Ni-MH	12 h	S.E.
60823	NICE-CS-250NM15SE65	250	90 min	Ni-MH	12 h	S.E.
60824	NICE-CS-250NM20SE65	250	120 min	Ni-MH	12 h	S.E.
60825	NICE-CS-300NM10SE65	300	60 min	Ni-MH	12 h	S.E.
60826	NICE-CS-300NM15SE65	300	90 min	Ni-MH	12 h	S.E.
60827	NICE-CS-300NM20SE65	300	120 min	Ni-MH	12 h	S.E.
60828	NICE-CS-400NM10SE65	400	60 min	Ni-MH	12 h	S.E.
60829	NICE-CS-400NM15SE65	400	90 min	Ni-MH	12 h	S.E.
60830	NICE-CS-500NM10SE65	500	60 min	Ni-MH	12 h	S.E.

NICE - CENTRAL SYSTEM S.E./S.A. IP65

CODICE	ARTICOLO	LUMEN S.E.	LUMEN S.A.	AUTONOMIA	BATTERIA	TEMPO DI RICARICA	MODO
60831	NICE-CS-100NM10SESA65	100	100	60 min	Ni-MH	12 h	S.E./S.A.
60832	NICE-CS-100NM15SESA65	100	100	90 min	Ni-MH	12 h	S.E./S.A.
60833	NICE-CS-100NM20SESA65	100	100	120 min	Ni-MH	12 h	S.E./S.A.
60834	NICE-CS-100NM30SESA65	100	100	180 min	Ni-MH	12 h	S.E./S.A.
60835	NICE-CS-150NM10SESA65	150	150	60 min	Ni-MH	12 h	S.E./S.A.
60836	NICE-CS-150NM15SESA65	150	150	90 min	Ni-MH	12 h	S.E./S.A.
60837	NICE-CS-150NM20SESA65	150	150	120 min	Ni-MH	12 h	S.E./S.A.
60838	NICE-CS-150NM30SESA65	150	150	180 min	Ni-MH	12 h	S.E./S.A.
60839	NICE-CS-200NM10SESA65	200	200	60 min	Ni-MH	12 h	S.E./S.A.
60840	NICE-CS-200NM15SESA65	200	200	90 min	Ni-MH	12 h	S.E./S.A.
60841	NICE-CS-200NM20SESA65	200	200	120 min	Ni-MH	12 h	S.E./S.A.
60842	NICE-CS-250NM10SESA65	250	250	60 min	Ni-MH	12 h	S.E./S.A.
60843	NICE-CS-250NM15SESA65	250	250	90 min	Ni-MH	12 h	S.E./S.A.
60844	NICE-CS-250NM20SESA65	250	250	120 min	Ni-MH	12 h	S.E./S.A.
60845	NICE-CS-300NM10SESA65	300	300	60 min	Ni-MH	12 h	S.E./S.A.
60846	NICE-CS-300NM15SESA65	300	300	90 min	Ni-MH	12 h	S.E./S.A.
60847	NICE-CS-300NM20SESA65	300	300	120 min	Ni-MH	12 h	S.E./S.A.
60848	NICE-CS-400NM10SESA65	400	400	60 min	Ni-MH	12 h	S.E./S.A.
60849	NICE-CS-400NM15SESA65	400	400	90 min	Ni-MH	12 h	S.E./S.A.
60850	NICE-CS-500NM10SESA65	500	500	60 min	Ni-MH	12 h	S.E./S.A.

NICE - S.O.S. GROUND 230V IP42

CODICE	ARTICOLO	LUMEN S.E.	ALIMENTAZIONE
60851	NICE-SOS-100-230-42	100	230V
60852	NICE-SOS-150-230-42	150	230V
60853	NICE-SOS-200-230-42	200	230V
60854	NICE-SOS-250-230-42	250	230V
60855	NICE-SOS-300-230-42	300	230V
60856	NICE-SOS-400-230-42	400	230V
60857	NICE-SOS-500-230-42	500	230V

NICE - S.O.S. GROUND 230V IP65

CODICE	ARTICOLO	LUMEN S.E.	ALIMENTAZIONE
60858	NICE-SOS-100-230-65	100	230V
60859	NICE-SOS-150-230-65	150	230V
60860	NICE-SOS-200-230-65	200	230V
60861	NICE-SOS-250-230-65	250	230V
60862	NICE-SOS-300-230-65	300	230V
60863	NICE-SOS-400-230-65	400	230V
60864	NICE-SOS-500-230-65	500	230V

NICE - S.O.S. 24V IP42

CODICE	ARTICOLO	LUMEN S.E.	ALIMENTAZIONE
61538	NICE-SOS-100-24-42	100	24V
61539	NICE-SOS-150-24-42	150	24V
61540	NICE-SOS-200-24-42	200	24V
61541	NICE-SOS-250-24-42	250	24V
61542	NICE-SOS-300-24-42	300	24V
61543	NICE-SOS-400-24-42	400	24V
61544	NICE-SOS-500-24-42	500	24V

NICE - S.O.S. 24V IP65

CODICE	ARTICOLO	LUMEN S.E.	ALIMENTAZIONE
61545	NICE-SOS-100-24-65	100	24V
61546	NICE-SOS-150-24-65	150	24V
61547	NICE-SOS-200-24-65	200	24V
61548	NICE-SOS-250-24-65	250	24V
61549	NICE-SOS-300-24-65	300	24V
61550	NICE-SOS-400-24-65	400	24V
61551	NICE-SOS-500-24-65	500	24V

NICE - SOLOLUCE 12-24V IP42

CODICE	ARTICOLO	LUMEN S.E.	ALIMENTAZIONE
60867	NICE-SL-100-1224-42	100	12-24V
60868	NICE-SL-150-1224-42	150	12-24V
60869	NICE-SL-200-1224-42	200	12-24V
60870	NICE-SL-250-1224-42	250	12-24V
60871	NICE-SL-300-1224-42	300	12-24V
60872	NICE-SL-400-1224-42	400	12-24V
60873	NICE-SL-500-1224-42	500	12-24V

NICE - SOLOLUCE 12-24V IP65					
CODICE	ARTICOLO	LUMEN S.E.	ALIMENTAZIONE		
60874	NICE-SL-100-1224-65	100	12-24V		
60875	NICE-SL-150-1224-65	150	12-24V		
60876	NICE-SL-200-1224-65	200	12-24V		
60877	NICE-SL-250-1224-65	250	12-24V		
60878	NICE-SL-300-1224-65	300	12-24V		
60879	NICE-SL-400-1224-65	400	12-24V		
60880	NICE-SL-500-1224-65	500	12-24V		
NICE - SOLOLUCE 48V IP42					
CODICE	ARTICOLO	LUMEN S.E.	ALIMENTAZIONE		
60881	NICE-SL-100-48-42	100	48V		
60882	NICE-SL-150-48-42	150	48V		
60883	NICE-SL-200-48-42	200	48V		
60884	NICE-SL-250-48-42	250	48V		
60885	NICE-SL-300-48-42	300	48V		
60886	NICE-SL-400-48-42	400	48V		
60887	NICE-SL-500-48-42	500	48V		
NICE - SOLOLUCE 48V IP65					
CODICE	ARTICOLO	LUMEN S.E.	ALIMENTAZIONE		
60888	NICE-SL-100-48-65	100	48V		
60889	NICE-SL-150-48-65	150	48V		
60890	NICE-SL-200-48-65	200	48V		
60891	NICE-SL-250-48-65	250	48V		
60892	NICE-SL-300-48-65	300	48V		
60893	NICE-SL-400-48-65	400	48V		
60894	NICE-SL-500-48-65	500	48V		
NICE - SOLOLUCE 230V IP42					
CODICE	ARTICOLO	LUMEN S.E.	ALIMENTAZIONE		
60895	NICE-SL-100-230-42	100	230V		
60896	NICE-SL-150-230-42	150	230V		
60897	NICE-SL-200-230-42	200	230V		
60898	NICE-SL-250-230-42	250	230V		
60899	NICE-SL-300-230-42	300	230V		
60900	NICE-SL-400-230-42	400	230V		
60901	NICE-SL-500-230-42	500	230V		
NICE - SOLOLUCE 230V IP65					
CODICE	ARTICOLO	LUMEN S.E.	ALIMENTAZIONE		
60902	NICE-SL-100-230-65	100	230V		
60903	NICE-SL-150-230-65	150	230V		
60904	NICE-SL-200-230-65	200	230V		
60905	NICE-SL-250-230-65	250	230V		
60906	NICE-SL-300-230-65	300	230V		
60907	NICE-SL-400-230-65	400	230V		
60908	NICE-SL-500-230-65	500	230V		

nice EKO



IDEALE PER INSTALLAZIONI IN AMBIENTI COME:

- UFFICI
- ABITAZIONI PRIVATE
- NEGOZI
- ALBERGHI

CARATTERISTICHE PRINCIPALI:



Dimensioni compatte



Ampia gamma
da 75 a 300 lumen



Adatta per interni ed
esterni (IP42 o IP65)

nice EKO

LAMPADA DI EMERGENZA A LED

Fabbricazione elettronica italiana al 100%
100% Italian electronics manufacturing

Alimentazione 230Vca -50Hz
230Vca -50Hz input Power

Grado di protezione IP42 o IP65
IP42 or IP65 protection degree

Grado di resistenza agli urti IK07
IK07 shock resistance degree

Materiale corpo in policarbonato autoestinguente V2
Self-extinguishing (V2) polycarbonate body material

Materiale diffusore in policarbonato autoestinguente V2
Self-extinguishing (V2) polycarbonate reflector material

Temperatura operativa 0°C / +40°C
0°C / +40°C working temperature

Glow wire test 850°C (2.0mm)
850°C (2.0mm) glow wire test

Tipo di funzionamento S.E. o S.E./S.A.
NOT PERMANENT or PERMANENT functioning

Autonomia da 60 a 180 minuti
From 60 to 180 minutes autonomy

Tempo di ricarica 12 ore
12 hours recharging time

Montaggio a parete
Wall mounting

Batteria Ni-MH ricaricabile, garantita 24 mesi
Rechargeable Ni-MH battery, 24 months warranty

Ricarica della batteria a corrente costante
Battery recharging at constant rated current

Protezione della batteria a scarica completa
Battery protection at full discharging

LED verde spia presenza rete
Green LED power ON

Fonte luminosa LED Alta efficienza
LED High efficiency Light source

Gamma flusso luminoso nominale da 75 a 300 Lumen
Luminous flux range from 75 to 300 Lumen

Resa cromatica (CRI) 80
80 colour rendering index

Temperatura colore 5000K
5000K colour temperature

Rischio fotobiologico ZERO secondo EN62471
Photobiological NO-risk according to EN62471

Garanzia sulla fonte luminosa LED di 10 anni
10 years warranty on LED light source

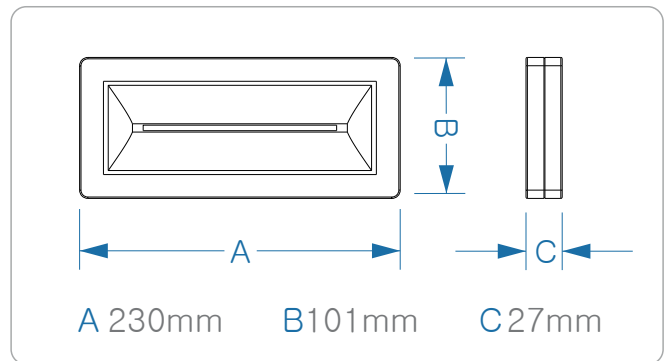
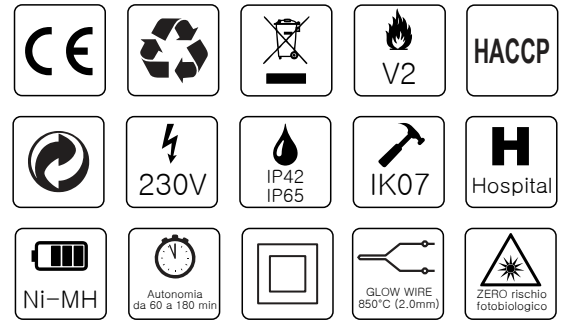

Le lampade IP65 vengono fornite con la guarnizione in silicone espanso già inserita + il raccordo tubo-lampada d. 16mm

IP65 lamps are supplied with the foam silicone gasket (already inserted) + tube-lamp junction d. 16mm

Diagramma polare
Polar diagram

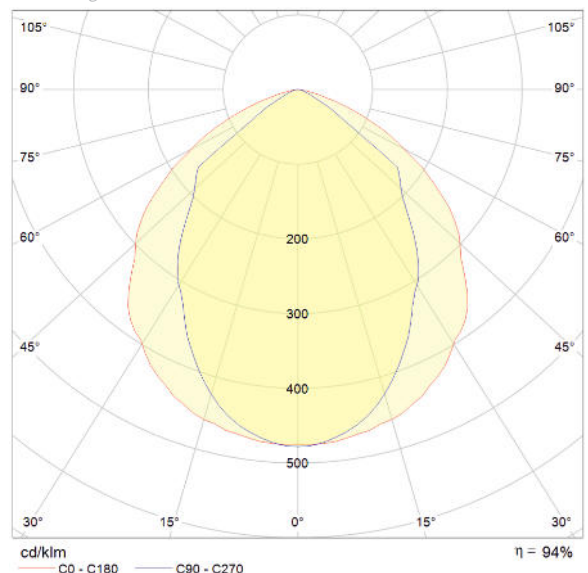

NICE EKO - STANDARD S.E. IP42							
CODICE	ARTICOLO	LUMEN S.E.	AUTONOMIA	BATTERIA	TEMPO DI RICARICA	MODO	
59216	NEK75NM10SE42	75	60 min	Ni-MH	12 h	S.E.	
59217	NEK75NM20SE42	75	120 min	Ni-MH	12 h	S.E.	
59218	NEK75NM30SE42	75	180 min	Ni-MH	12 h	S.E.	
59219	NEK90NM10SE42	90	60 min	Ni-MH	12 h	S.E.	
59220	NEK90NM20SE42	90	120 min	Ni-MH	12 h	S.E.	
59221	NEK90NM30SE42	90	180 min	Ni-MH	12 h	S.E.	
59222	NEK120NM10SE42	120	60 min	Ni-MH	12 h	S.E.	
59223	NEK120NM20SE42	120	120 min	Ni-MH	12 h	S.E.	
59224	NEK120NM30SE42	120	180 min	Ni-MH	12 h	S.E.	
59225	NEK150NM10SE42	150	60 min	Ni-MH	12 h	S.E.	
59226	NEK150NM20SE42	150	120 min	Ni-MH	12 h	S.E.	
59227	NEK150NM30SE42	150	180 min	Ni-MH	12 h	S.E.	
59228	NEK200NM10SE42	200	60 min	Ni-MH	12 h	S.E.	
59229	NEK200NM20SE42	200	120 min	Ni-MH	12 h	S.E.	
59230	NEK200NM30SE42	200	180 min	Ni-MH	12 h	S.E.	
59231	NEK250NM10SE42	250	60 min	Ni-MH	12 h	S.E.	
59232	NEK250NM20SE42	250	120 min	Ni-MH	12 h	S.E.	
59233	NEK250NM25SE42	250	150 min	Ni-MH	12 h	S.E.	
59234	NEK300NM10SE42	300	60 min	Ni-MH	12 h	S.E.	
59235	NEK300NM20SE42	300	120 min	Ni-MH	12 h	S.E.	

NICE EKO - STANDARD S.E./S.A. IP42							
CODICE	ARTICOLO	LUMEN S.E.	LUMEN S.A.	AUTONOMIA	BATTERIA	TEMPO DI RICARICA	MODO
59243	NEK75NM10SESA42	75	75	60 min	Ni-MH	12 h	S.E./S.A.
59244	NEK75NM20SESA42	75	75	120 min	Ni-MH	12 h	S.E./S.A.
59245	NEK75NM30SESA42	75	75	180 min	Ni-MH	12 h	S.E./S.A.
59246	NEK90NM10SESA42	90	90	60 min	Ni-MH	12 h	S.E./S.A.
59247	NEK90NM20SESA42	90	90	120 min	Ni-MH	12 h	S.E./S.A.
59248	NEK90NM30SESA42	90	90	180 min	Ni-MH	12 h	S.E./S.A.
59249	NEK120NM10SESA42	120	120	60 min	Ni-MH	12 h	S.E./S.A.
59250	NEK120NM20SESA42	120	120	120 min	Ni-MH	12 h	S.E./S.A.
59251	NEK120NM30SESA42	120	120	180 min	Ni-MH	12 h	S.E./S.A.
59252	NEK150NM10SESA42	150	150	60 min	Ni-MH	12 h	S.E./S.A.
59253	NEK150NM20SESA42	150	150	120 min	Ni-MH	12 h	S.E./S.A.
59254	NEK150NM30SESA42	150	150	180 min	Ni-MH	12 h	S.E./S.A.
59255	NEK200NM10SESA42	200	170	60 min	Ni-MH	12 h	S.E./S.A.
59256	NEK200NM20SESA42	200	170	120 min	Ni-MH	12 h	S.E./S.A.
59257	NEK200NM30SESA42	200	170	180 min	Ni-MH	12 h	S.E./S.A.
59258	NEK250NM10SESA42	250	170	60 min	Ni-MH	12 h	S.E./S.A.
59259	NEK250NM20SESA42	250	170	120 min	Ni-MH	12 h	S.E./S.A.
59260	NEK250NM25SESA42	250	170	150 min	Ni-MH	12 h	S.E./S.A.
59261	NEK300NM10SESA42	300	170	60 min	Ni-MH	12 h	S.E./S.A.
59262	NEK300NM20SESA42	300	170	120 min	Ni-MH	12 h	S.E./S.A.

NICE EKO - STANDARD S.E. IP65							
CODICE	ARTICOLO	LUMEN S.E.	AUTONOMIA	BATTERIA	TEMPO DI RICARICA	MODO	
56261	NEK75NM10SE65	75	60 min	Ni-MH	12 h	S.E.	
56262	NEK75NM20SE65	75	120 min	Ni-MH	12 h	S.E.	
56263	NEK75NM30SE65	75	180 min	Ni-MH	12 h	S.E.	
56264	NEK90NM10SE65	90	60 min	Ni-MH	12 h	S.E.	
56265	NEK90NM20SE65	90	120 min	Ni-MH	12 h	S.E.	
56266	NEK90NM30SE65	90	180 min	Ni-MH	12 h	S.E.	
56267	NEK120NM10SE65	120	60 min	Ni-MH	12 h	S.E.	
56268	NEK120NM20SE65	120	120 min	Ni-MH	12 h	S.E.	
56269	NEK120NM30SE65	120	180 min	Ni-MH	12 h	S.E.	
56270	NEK150NM10SE65	150	60 min	Ni-MH	12 h	S.E.	
56271	NEK150NM20SE65	150	120 min	Ni-MH	12 h	S.E.	
56272	NEK150NM30SE65	150	180 min	Ni-MH	12 h	S.E.	
56273	NEK200NM10SE65	200	60 min	Ni-MH	12 h	S.E.	
56274	NEK200NM20SE65	200	120 min	Ni-MH	12 h	S.E.	
56275	NEK200NM30SE65	200	180 min	Ni-MH	12 h	S.E.	
56276	NEK250NM10SE65	250	60 min	Ni-MH	12 h	S.E.	
56277	NEK250NM20SE65	250	120 min	Ni-MH	12 h	S.E.	
56278	NEK250NM25SE65	250	150 min	Ni-MH	12 h	S.E.	
56279	NEK300NM10SE65	300	60 min	Ni-MH	12 h	S.E.	
56280	NEK300NM20SE65	300	120 min	Ni-MH	12 h	S.E.	

NICE EKO - STANDARD S.E./S.A. IP65							
CODICE	ARTICOLO	LUMEN S.E.	LUMEN S.A.	AUTONOMIA	BATTERIA	TEMPO DI RICARICA	MODO
56281	NEK75NM10SESA65	75	75	60 min	Ni-MH	12 h	S.E./S.A.
56282	NEK75NM20SESA65	75	75	120 min	Ni-MH	12 h	S.E./S.A.
56283	NEK75NM30SESA65	75	75	180 min	Ni-MH	12 h	S.E./S.A.
56284	NEK90NM10SESA65	90	90	60 min	Ni-MH	12 h	S.E./S.A.
56285	NEK90NM20SESA65	90	90	120 min	Ni-MH	12 h	S.E./S.A.
56286	NEK90NM30SESA65	90	90	180 min	Ni-MH	12 h	S.E./S.A.
56287	NEK120NM10SESA65	120	120	60 min	Ni-MH	12 h	S.E./S.A.
56288	NEK120NM20SESA65	120	120	120 min	Ni-MH	12 h	S.E./S.A.
56289	NEK120NM30SESA65	120	120	180 min	Ni-MH	12 h	S.E./S.A.

56290	NEK150NM10SESA65	150	150	60 min	Ni-MH	12 h	S.E./S.A.
56291	NEK150NM20SESA65	150	150	120 min	Ni-MH	12 h	S.E./S.A.
56292	NEK150NM30SESA65	150	150	180 min	Ni-MH	12 h	S.E./S.A.
56293	NEK200NM10SESA65	200	170	60 min	Ni-MH	12 h	S.E./S.A.
56294	NEK200NM20SESA65	200	170	120 min	Ni-MH	12 h	S.E./S.A.
56295	NEK200NM30SESA65	200	170	180 min	Ni-MH	12 h	S.E./S.A.
56296	NEK250NM10SESA65	250	170	60 min	Ni-MH	12 h	S.E./S.A.
56297	NEK250NM20SESA65	250	170	120 min	Ni-MH	12 h	S.E./S.A.
56298	NEK250NM25SESA65	250	170	150 min	Ni-MH	12 h	S.E./S.A.
56299	NEK300NM10SESA65	300	170	60 min	Ni-MH	12 h	S.E./S.A.
56300	NEK300NM20SESA65	300	170	120 min	Ni-MH	12 h	S.E./S.A.

ISTRUZIONI LAMPADE NICE IP65

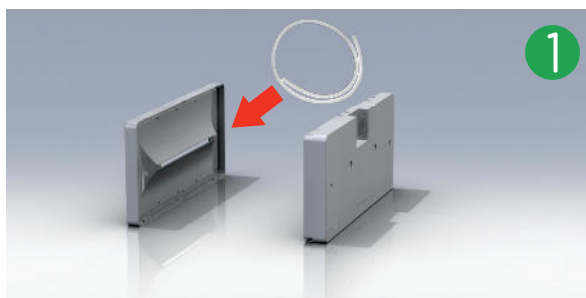

1 • La lampada viene fornita con la guarnizione in silicone espanso già inserita nel suo alloggiamento.



2 • Rimuovere l'aletta pretranciata sulla parte superiore della lampada per permettere l'inserimento del raccordo passatubo Ø 16.

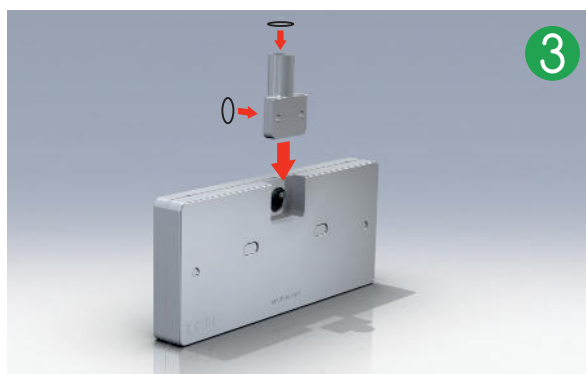

3 • Applicare gli o-ring nel raccordo ed inserire quest'ultimo nella sede facendo passare i fili al suo interno.

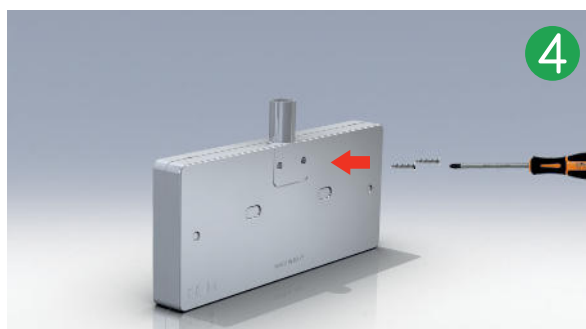

4 • Avvitare le viti autofilettanti per permettere all'o-ring di premere, evitando così l'entrata di polvere ed acqua, garantendo un grado di protezione IP65.

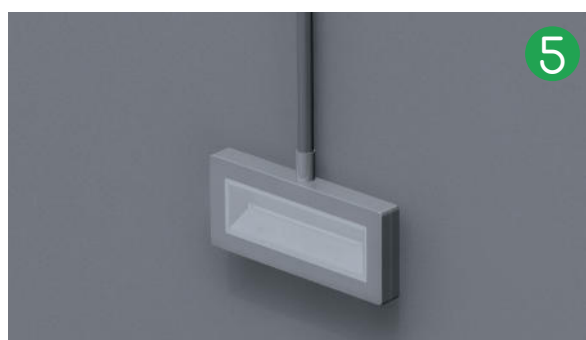







5 • Inserire il tubo nel raccordo e installare la lampada a parete o a soffitto.

ACCESSORI

nice & nice EKO

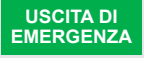
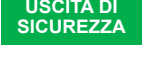

CODICE	ARTICOLO		DESCRIZIONE
60954	GIX-NICE		GABBIA DI PROTEZIONE PER LAMPADE NICE
17648	ATC-45-FST		STAFFA PER INSTALLAZIONE ORIENTABILE A 45° IN ACCIAIO INOX
56307	PITT-NICE-DX		PITTOGRAMMA PER LAMPADE NICE FRECCIA DESTRA
56308	PITT-NICE-SX		PITTOGRAMMA PER LAMPADE NICE FRECCIA SINISTRA
56309	PITT-NICE-DOWN		PITTOGRAMMA PER LAMPADE NICE FRECCIA GIU
56310	PITT-NICE-US-EM		PITTOGRAMMA PER LAMPADE NICE USCITA DI EMERGENZA
56311	PITT-NICE-US-SIC		PITTOGRAMMA PER LAMPADE NICE USCITA DI SICUREZZA
56312	KIT-PITT-NICE		<ul style="list-style-type: none"> •1x Freccia DOWN •1x Freccia DX •1x Freccia SX



GARANZIA ACCUMULATORI 24 MESI:

-LE BATTERIE NICKEL METAL HYDRIDE E QUELLE AL LiPo-FERRO ALL'INTERNO DELLE NOSTRE LAMPADE DI EMERGENZA, SONO COPERTE DA GARANZIA DI 24 MESI DALL'ACQUISTO COMPROVATO DAL DOCUMENTO FISCALE. IMPORTANTE LEGGERE E CONSIDERARE LE CONDIZIONI GENERALI DI GARANZIA ACCUMULATORI DELLA "ELETTRONICA KROS"

-POSSIBILITA' DI ESTENSIONE GARANZIA ACCUMULATORI. SARETE POI CONTATTATI PER I TERMINI DI ESTENSIONE.

FARE RICHIESTA A: oem@elettronica-kros.it

GARANZIA FONTE LUMINOSA LED 1 O ANNI DI GARANZIA
IMPORTANTE LEGGERE E CONSIDERARE LE CONDIZIONI GENERALI DI GARANZIA

Indice progressivo

Codice	Articolo	Pagina	Codice	Articolo	Pagina	Codice	Articolo	Pagina
56261	NEK75NM10SE65	11	59254	NEK150NM30SESA42	11	59439	NICE200NM20SESA42-24H	3
56262	NEK75NM20SE65	11	59255	NEK200NM10SESA42	11	59440	NICE200NM30SESA42-24H	3
56263	NEK75NM30SE65	11	59256	NEK200NM20SESA42	11	59441	NICE230NM10SESA42-24H	3
56264	NEK90NM10SE65	11	59257	NEK200NM30SESA42	11	59442	NICE230NM15SESA42-24H	3
56265	NEK90NM20SE65	11	59258	NEK250NM10SESA42	11	59443	NICE230NM20SESA42-24H	4
56266	NEK90NM30SE65	11	59259	NEK250NM20SESA42	11	59444	NICE300NM10SESA42-24H	4
56267	NEK120NM10SE65	11	59260	NEK250NM25SESA42	11	59445	NICE300NM15SESA42-24H	4
56268	NEK120NM20SE65	11	59261	NEK300NM10SESA42	11	59446	NICE300NM20SESA42-24H	4
56269	NEK120NM30SE65	11	59262	NEK300NM20SESA42	11	59447	NICE380NM10SESA42-24H	4
56270	NEK150NM10SE65	11	59371	NICE75NM10SE42	3	59448	NICE380NM15SESA42-24H	4
56271	NEK150NM20SE65	11	59372	NICE75NM15SE42	3	59449	NICE75NM10SE65	4
56272	NEK150NM30SE65	11	59373	NICE75NM20SE42	3	59450	NICE75NM15SE65	4
56273	NEK200NM10SE65	11	59374	NICE75NM30SE42	3	59451	NICE75NM20SE65	4
56274	NEK200NM20SE65	11	59375	NICE90NM10SE42	3	59452	NICE75NM30SE65	4
56275	NEK200NM30SE65	11	59376	NICE90NM15SE42	3	59453	NICE90NM10SE65	4
56276	NEK250NM10SE65	11	59377	NICE90NM20SE42	3	59454	NICE90NM15SE65	4
56277	NEK250NM20SE65	11	59378	NICE90NM30SE42	3	59455	NICE90NM20SE65	4
56278	NEK250NM25SE65	11	59379	NICE115NM10SE42	3	59456	NICE90NM30SE65	4
56279	NEK300NM10SE65	11	59380	NICE115NM15SE42	3	59457	NICE115NM10SE65	4
56280	NEK300NM20SE65	11	59381	NICE115NM20SE42	3	59458	NICE115NM15SE65	4
56281	NEK75NM10SESA65	11	59382	NICE115NM30SE42	3	59459	NICE115NM20SE65	4
56282	NEK75NM20SESA65	11	59383	NICE150NM10SE42	3	59460	NICE115NM30SE65	4
56283	NEK75NM30SESA65	11	59384	NICE150NM15SE42	3	59461	NICE150NM10SE65	4
56284	NEK90NM10SESA65	11	59385	NICE150NM20SE42	3	59462	NICE150NM15SE65	4
56285	NEK90NM20SESA65	11	59386	NICE150NM30SE42	3	59463	NICE150NM20SE65	4
56286	NEK90NM30SESA65	11	59387	NICE200NM10SE42	3	59464	NICE150NM30SE65	4
56287	NEK120NM10SESA65	11	59388	NICE200NM15SE42	3	59465	NICE200NM10SE65	4
56288	NEK120NM20SESA65	11	59389	NICE200NM20SE42	3	59466	NICE200NM15SE65	4
56289	NEK120NM30SESA65	11	59390	NICE200NM30SE42	3	59467	NICE200NM20SE65	4
56290	NEK150NM10SESA65	12	59391	NICE230NM10SE42	3	59468	NICE200NM30SE65	4
56291	NEK150NM20SESA65	12	59392	NICE230NM15SE42	3	59469	NICE230NM10SE65	4
56292	NEK150NM30SESA65	12	59393	NICE230NM20SE42	3	59470	NICE230NM15SE65	4
56293	NEK200NM10SESA65	12	59394	NICE300NM10SE42	3	59471	NICE230NM20SE65	4
56294	NEK200NM20SESA65	12	59395	NICE300NM15SE42	3	59472	NICE300NM10SE65	4
56295	NEK200NM30SESA65	12	59396	NICE300NM20SE42	3	59473	NICE300NM15SE65	4
56296	NEK250NM10SESA65	12	59397	NICE380NM10SE42	3	59474	NICE300NM20SE65	4
56297	NEK250NM20SESA65	12	59398	NICE380NM15SE42	3	59475	NICE380NM10SE65	4
56298	NEK250NM25SESA65	12	59399	NICE75NM10SESA42	3	59476	NICE380NM15SE65	4
56299	NEK300NM10SESA65	12	59400	NICE75NM15SESA42	3	59477	NICE75NM10SESA65	4
56300	NEK300NM20SESA65	12	59401	NICE75NM20SESA42	3	59478	NICE75NM15SESA65	4
56301	PITT-NICE-DX	14	59402	NICE75NM30SESA42	3	59479	NICE75NM20SESA65	4
56302	PITT-NICE-SX	14	59403	NICE90NM10SESA42	3	59480	NICE75NM30SESA65	4
56303	PITT-NICE-DOWN	14	59404	NICE90NM15SESA42	3	59481	NICE90NM10SESA65	4
56310	PITT-NICE-US-EM	14	59405	NICE90NM20SESA42	3	59482	NICE90NM15SESA65	4
56311	PITT-NICE-US-SIC	14	59406	NICE90NM30SESA42	3	59483	NICE90NM20SESA65	4
56312	KIT-PITT-NICE	14	59407	NICE115NM10SESA42	3	59484	NICE90NM30SESA65	4
59216	NEK75NM10SE42	11	59408	NICE115NM15SESA42	3	59485	NICE115NM10SESA65	4
59217	NEK75NM20SE42	11	59409	NICE115NM20SESA42	3	59486	NICE115NM15SESA65	4
59218	NEK75NM30SE42	11	59410	NICE115NM30SESA42	3	59487	NICE115NM20SESA65	4
59219	NEK90NM10SE42	11	59411	NICE150NM10SESA42	3	59488	NICE115NM30SESA65	4
59220	NEK90NM20SE42	11	59412	NICE150NM15SESA42	3	59489	NICE150NM10SESA65	4
59221	NEK90NM30SE42	11	59413	NICE150NM20SESA42	3	59490	NICE150NM15SESA65	4
59222	NEK120NM10SE42	11	59414	NICE200NM10SESA42	3	59491	NICE150NM20SESA65	4
59223	NEK120NM20SE42	11	59415	NICE200NM15SESA42	3	59492	NICE200NM10SESA65	4
59224	NEK120NM30SE42	11	59416	NICE200NM20SESA42	3	59493	NICE200NM15SESA65	4
59225	NEK150NM10SE42	11	59417	NICE230NM10SESA42	3	59494	NICE200NM20SESA65	4
59226	NEK150NM20SE42	11	59418	NICE230NM15SESA42	3	59495	NICE230NM10SESA65	4
59227	NEK150NM30SE42	11	59419	NICE300NM10SESA42	3	59496	NICE230NM15SESA65	4
59228	NEK200NM10SE42	11	59420	NICE380NM10SESA42	3	59497	NICE300NM10SESA65	4
59229	NEK200NM20SE42	11	59421	NICE380NM15SESA42	3	59498	NICE380NM10SESA65	4
59230	NEK200NM30SE42	11	59422	NICE75NM10SESA42-24H	3	59499	NICE75NM10SESA65-24H	4
59231	NEK250NM10SE42	11	59423	NICE75NM15SESA42-24H	3	59500	NICE75NM15SESA65-24H	4
59232	NEK250NM20SE42	11	59424	NICE75NM20SESA42-24H	3	59501	NICE75NM20SESA65-24H	4
59233	NEK250NM25SE42	11	59425	NICE90NM10SESA42-24H	3	59502	NICE75NM30SESA65-24H	4
59234	NEK300NM10SE42	11	59426	NICE90NM15SESA42-24H	3	59503	NICE90NM10SESA65-24H	4
59235	NEK300NM20SE42	11	59427	NICE90NM20SESA42-24H	3	59504	NICE90NM15SESA65-24H	4
59243	NEK75NM10SESA42	11	59428	NICE90NM30SESA42-24H	3	59505	NICE90NM20SESA65-24H	4
59244	NEK75NM20SESA42	11	59429	NICE115NM10SESA42-24H	3	59506	NICE90NM30SESA65-24H	4
59245	NEK75NM30SESA42	11	59430	NICE115NM15SESA42-24H	3	59507	NICE115NM10SESA65-24H	4
59246	NEK90NM10SESA42	11	59431	NICE115NM20SESA42-24H	3	59508	NICE115NM15SESA65-24H	4
59247	NEK90NM20SESA42	11	59432	NICE115NM30SESA42-24H	3	59509	NICE115NM20SESA65-24H	4
59248	NEK90NM30SESA42	11	59433	NICE150NM10SESA42-24H	3	59510	NICE115NM30SESA65-24H	4
59249	NEK120NM10SESA42	11	59434	NICE150NM15SESA42-24H	3	59511	NICE150NM10SESA65-24H	4
59250	NEK120NM20SESA42	11	59435	NICE150NM20SESA42-24H	3	59512	NICE150NM15SESA65-24H	4
59251	NEK120NM30SESA42	11	59436	NICE150NM30SESA42-24H	3	59513	NICE150NM20SESA65-24H	4
59252	NEK150NM10SESA42	11	59437	NICE200NM10SESA42-24H	3	59514	NICE150NM30SESA65-24H	4
59253	NEK150NM20SESA42	11	59438	NICE200NM15SESA42-24H	3	59515	NICE200NM10SESA65-24H	5

Codice	Articolo	Pagina	Codice	Articolo	Pagina	Codice	Articolo	Pagina
59516	NICE200NM15SESA65-24H	5	60759	NICE-AT-200NM10SESA65	6	60840	NICE-CS-200NM15SESA65	7
59517	NICE200NM20SESA65-24H	5	60760	NICE-AT-200NM15SESA65	6	60841	NICE-CS-200NM20SESA65	7
59518	NICE200NM30SESA65-24H	5	60761	NICE-AT-200NM20SESA65	6	60842	NICE-CS-250NM10SESA65	7
59519	NICE230NM10SESA65-24H	5	60762	NICE-AT-250NM10SESA65	6	60843	NICE-CS-250NM15SESA65	7
59520	NICE230NM15SESA65-24H	5	60763	NICE-AT-250NM15SESA65	6	60844	NICE-CS-250NM20SESA65	7
59521	NICE230NM20SESA65-24H	5	60764	NICE-AT-250NM20SESA65	6	60845	NICE-CS-300NM10SESA65	7
59522	NICE300NM10SESA65-24H	5	60765	NICE-AT-300NM10SESA65	6	60846	NICE-CS-300NM15SESA65	7
59523	NICE300NM15SESA65-24H	5	60766	NICE-AT-300NM15SESA65	6	60847	NICE-CS-300NM20SESA65	7
59524	NICE300NM20SESA65-24H	5	60767	NICE-AT-300NM20SESA65	6	60848	NICE-CS-400NM10SESA65	7
59525	NICE380NM10SESA65-24H	5	60768	NICE-AT-400NM10SESA65	6	60849	NICE-CS-400NM15SESA65	7
59526	NICE380NM15SESA65-24H	5	60769	NICE-AT-400NM15SESA65	6	60850	NICE-CS-500NM10SESA65	7
60688	NICE500NM10SE42	3	60770	NICE-AT-500NM10SESA65	6	60851	NICE-SOS-100-230-42	7
60689	NICE500NM10SE65	4	60771	NICE-CS-100NM10SE42	6	60852	NICE-SOS-150-230-42	7
60691	NICE-AT-100NM10SE42	5	60772	NICE-CS-100NM15SE42	6	60853	NICE-SOS-200-230-42	7
60692	NICE-AT-100NM15SE42	5	60773	NICE-CS-100NM20SE42	6	60854	NICE-SOS-250-230-42	7
60693	NICE-AT-100NM20SE42	5	60774	NICE-CS-100NM30SE42	6	60855	NICE-SOS-300-230-42	7
60694	NICE-AT-100NM30SE42	5	60775	NICE-CS-150NM10SE42	6	60856	NICE-SOS-400-230-42	7
60695	NICE-AT-150NM10SE42	5	60776	NICE-CS-150NM15SE42	6	60857	NICE-SOS-500-230-42	7
60696	NICE-AT-150NM15SE42	5	60777	NICE-CS-150NM20SE42	6	60858	NICE-SOS-100-230-65	7
60697	NICE-AT-150NM20SE42	5	60778	NICE-CS-150NM30SE42	6	60859	NICE-SOS-150-230-65	7
60698	NICE-AT-150NM30SE42	5	60779	NICE-CS-200NM10SE42	6	60860	NICE-SOS-200-230-65	7
60699	NICE-AT-200NM10SE42	5	60780	NICE-CS-200NM15SE42	6	60861	NICE-SOS-250-230-65	7
60700	NICE-AT-200NM15SE42	5	60781	NICE-CS-200NM20SE42	6	60862	NICE-SOS-300-230-65	7
60701	NICE-AT-200NM20SE42	5	60782	NICE-CS-250NM10SE42	6	60863	NICE-SOS-400-230-65	7
60702	NICE-AT-250NM10SE42	5	60783	NICE-CS-250NM15SE42	6	60864	NICE-SOS-500-230-65	7
60703	NICE-AT-250NM15SE42	5	60784	NICE-CS-250NM20SE42	6	60867	NICE-SL-100-1224-42	7
60704	NICE-AT-250NM20SE42	5	60785	NICE-CS-300NM10SE42	6	60868	NICE-SL-150-1224-42	7
60705	NICE-AT-300NM10SE42	5	60786	NICE-CS-300NM15SE42	6	60869	NICE-SL-200-1224-42	7
60706	NICE-AT-300NM15SE42	5	60787	NICE-CS-300NM20SE42	6	60870	NICE-SL-250-1224-42	7
60707	NICE-AT-300NM20SE42	5	60788	NICE-CS-400NM10SE42	6	60871	NICE-SL-300-1224-42	7
60708	NICE-AT-400NM10SE42	5	60789	NICE-CS-400NM15SE42	6	60872	NICE-SL-400-1224-42	7
60709	NICE-AT-400NM15SE42	5	60790	NICE-CS-400NM20SE42	6	60873	NICE-SL-500-1224-42	7
60710	NICE-AT-500NM10SE42	5	60791	NICE-CS-100NM10SESA42	6	60874	NICE-SL-100-1224-65	8
60711	NICE-AT-100NM10SESA42	5	60792	NICE-CS-100NM15SESA42	6	60875	NICE-SL-150-1224-65	8
60712	NICE-AT-100NM15SESA42	5	60793	NICE-CS-100NM20SESA42	6	60876	NICE-SL-200-1224-65	8
60713	NICE-AT-100NM20SESA42	5	60794	NICE-CS-100NM30SESA42	6	60877	NICE-SL-250-1224-65	8
60714	NICE-AT-100NM30SESA42	5	60795	NICE-CS-150NM10SESA42	6	60878	NICE-SL-300-1224-65	8
60715	NICE-AT-150NM10SESA42	5	60796	NICE-CS-150NM15SESA42	6	60879	NICE-SL-400-1224-65	8
60716	NICE-AT-150NM15SESA42	5	60797	NICE-CS-150NM20SESA42	6	60880	NICE-SL-500-1224-65	8
60717	NICE-AT-150NM20SESA42	5	60798	NICE-CS-150NM30SESA42	6	60881	NICE-SL-100-48-42	8
60718	NICE-AT-150NM30SESA42	5	60799	NICE-CS-200NM10SESA42	6	60882	NICE-SL-150-48-42	8
60719	NICE-AT-200NM10SESA42	5	60800	NICE-CS-200NM15SESA42	6	60883	NICE-SL-200-48-42	8
60720	NICE-AT-200NM15SESA42	5	60801	NICE-CS-200NM20SESA42	6	60884	NICE-SL-250-48-42	8
60721	NICE-AT-200NM20SESA42	5	60802	NICE-CS-250NM10SESA42	6	60885	NICE-SL-300-48-42	8
60722	NICE-AT-250NM10SESA42	5	60803	NICE-CS-250NM15SESA42	6	60886	NICE-SL-400-48-42	8
60723	NICE-AT-250NM15SESA42	5	60804	NICE-CS-250NM20SESA42	6	60887	NICE-SL-500-48-42	8
60724	NICE-AT-250NM20SESA42	5	60805	NICE-CS-300NM10SESA42	6	60888	NICE-SL-100-48-65	8
60725	NICE-AT-300NM10SESA42	5	60806	NICE-CS-300NM15SESA42	6	60889	NICE-SL-150-48-65	8
60726	NICE-AT-300NM15SESA42	5	60807	NICE-CS-300NM20SESA42	6	60890	NICE-SL-200-48-65	8
60727	NICE-AT-300NM20SESA42	5	60808	NICE-CS-400NM10SESA42	6	60891	NICE-SL-250-48-65	8
60728	NICE-AT-400NM10SESA42	5	60809	NICE-CS-400NM15SESA42	6	60892	NICE-SL-300-48-65	8
60729	NICE-AT-400NM15SESA42	5	60810	NICE-CS-500NM10SESA42	6	60893	NICE-SL-400-48-65	8
60730	NICE-AT-500NM10SESA42	5	60811	NICE-CS-100NM10SE65	6	60894	NICE-SL-500-48-65	8
60731	NICE-AT-100NM10SE65	5	60812	NICE-CS-100NM15SE65	6	60895	NICE-SL-100-230-42	8
60732	NICE-AT-100NM15SE65	5	60813	NICE-CS-100NM20SE65	6	60896	NICE-SL-150-230-42	8
60733	NICE-AT-100NM20SE65	5	60814	NICE-CS-100NM30SE65	6	60897	NICE-SL-200-230-42	8
60734	NICE-AT-100NM30SE65	5	60815	NICE-CS-150NM10SE65	6	60898	NICE-SL-250-230-42	8
60735	NICE-AT-150NM10SE65	5	60816	NICE-CS-150NM15SE65	6	60899	NICE-SL-300-230-42	8
60736	NICE-AT-150NM15SE65	5	60817	NICE-CS-150NM20SE65	6	60900	NICE-SL-400-230-42	8
60737	NICE-AT-150NM20SE65	5	60818	NICE-CS-150NM30SE65	6	60901	NICE-SL-500-230-42	8
60738	NICE-AT-150NM30SE65	5	60819	NICE-CS-200NM10SE65	6	60902	NICE-SL-100-230-65	8
60739	NICE-AT-200NM10SE65	5	60820	NICE-CS-200NM15SE65	6	60903	NICE-SL-150-230-65	8
60740	NICE-AT-200NM15SE65	5	60821	NICE-CS-200NM20SE65	6	60904	NICE-SL-200-230-65	8
60741	NICE-AT-200NM20SE65	5	60822	NICE-CS-250NM10SE65	7	60905	NICE-SL-250-230-65	8
60742	NICE-AT-250NM10SE65	5	60823	NICE-CS-250NM15SE65	7	60906	NICE-SL-300-230-65	8
60743	NICE-AT-250NM15SE65	5	60824	NICE-CS-250NM20SE65	7	60907	NICE-SL-400-230-65	8
60744	NICE-AT-250NM20SE65	5	60825	NICE-CS-300NM10SE65	7	60908	NICE-SL-500-230-65	8
60745	NICE-AT-300NM10SE65	5	60826	NICE-CS-300NM15SE65	7	61538	NICE-SOS-100-24-42	7
60746	NICE-AT-300NM15SE65	5	60827	NICE-CS-300NM20SE65	7	61539	NICE-SOS-150-24-42	7
60747	NICE-AT-300NM20SE65	5	60828	NICE-CS-400NM10SE65	7	61540	NICE-SOS-200-24-42	7
60748	NICE-AT-400NM10SE65	5	60829	NICE-CS-400NM15SE65	7	61541	NICE-SOS-250-24-42	7
60749	NICE-AT-400NM15SE65	5	60830	NICE-CS-500NM10SE65	7	61542	NICE-SOS-300-24-42	7
60750	NICE-AT-500NM10SE65	5	60831	NICE-CS-100NM10SESA65	7	61543	NICE-SOS-400-24-42	7
60751	NICE-AT-100NM10SESA65	6	60832	NICE-CS-100NM15SESA65	7	61544	NICE-SOS-500-24-42	7
60752	NICE-AT-100NM15SESA65	6	60833	NICE-CS-100NM20SESA65	7	61545	NICE-SOS-100-24-65	7
60753	NICE-AT-100NM20SESA65	6	60834	NICE-CS-100NM30SESA65	7	61546	NICE-SOS-150-24-65	7
60754	NICE-AT-100NM30SESA65	6	60835	NICE-CS-150NM10SESA65	7	61547	NICE-SOS-200-24-65	7
60755	NICE-AT-150NM10SESA65	6	60836	NICE-CS-150NM15SESA65	7	61548	NICE-SOS-250-24-65	7
60756	NICE-AT-150NM15SESA65	6	60837	NICE-CS-150NM20SESA65	7	61549	NICE-SOS-300-24-65	7
60757	NICE-AT-150NM20SESA65	6	60838	NICE-CS-150NM30SESA65	7	61550	NICE-SOS-400-24-65	7
60758	NICE-AT-150NM30SESA65	6	60839	NICE-CS-200NM10SESA65	7	61551	NICE-SOS-500-24-65	7

PROGETTAZIONE ILLUMINOTECNICA

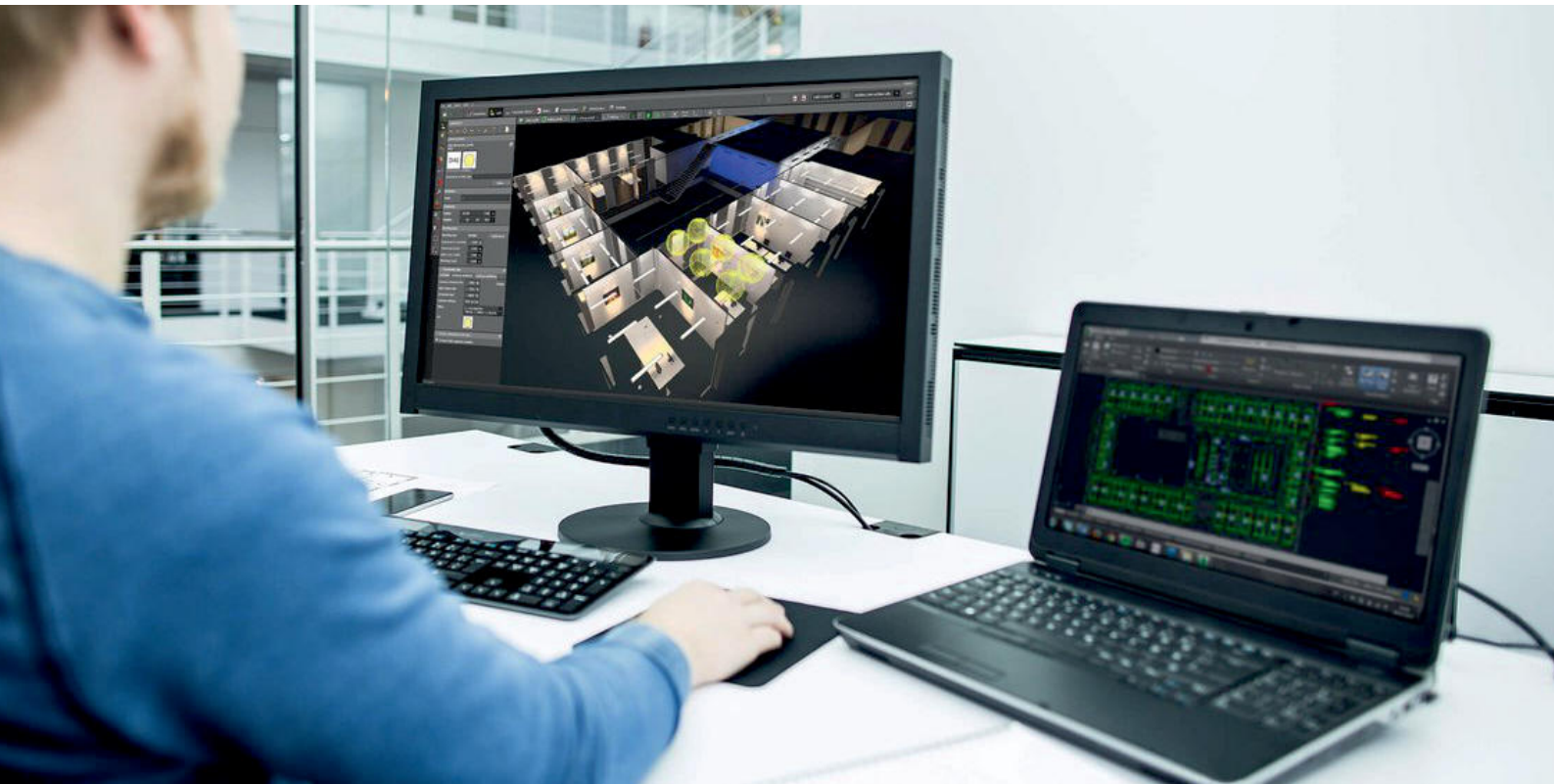

I nostri specialisti possono sviluppare calcoli illuminotecnici, emulando un'illuminazione di emergenza specifica ed adeguata per ogni tipo di impianto, indicando i giusti prodotti adatti a garantire l'illuminazione media richiesta dalle normative del caso. Avere un file DWG della planimetria dell'impianto è un vantaggio notevole per ricreare perfettamente la struttura da illuminare.

RICHIEDICI IL PROGETTO ILLUMINOTECNICO FORNENDOCI LE INFORMAZIONI NECESSARIE

I dati principali per sviluppare un progetto di illuminazione di emergenza sono:

- Dimensioni della superficie da illuminare (Lunghezza, Larghezza, Altezza)
- Tipologia della struttura (Albergo, Supermercato, Scuola, Ospedale, ecc.)
- Altezza e tipo di montaggio dei corpi illuminanti (h 3m Soffitto, h 2.5m Parete ecc.)
- Modalità di emergenza richiesta (Standard, Autotesting, Centralizzata ecc.)
- Colorazione pavimento e pareti

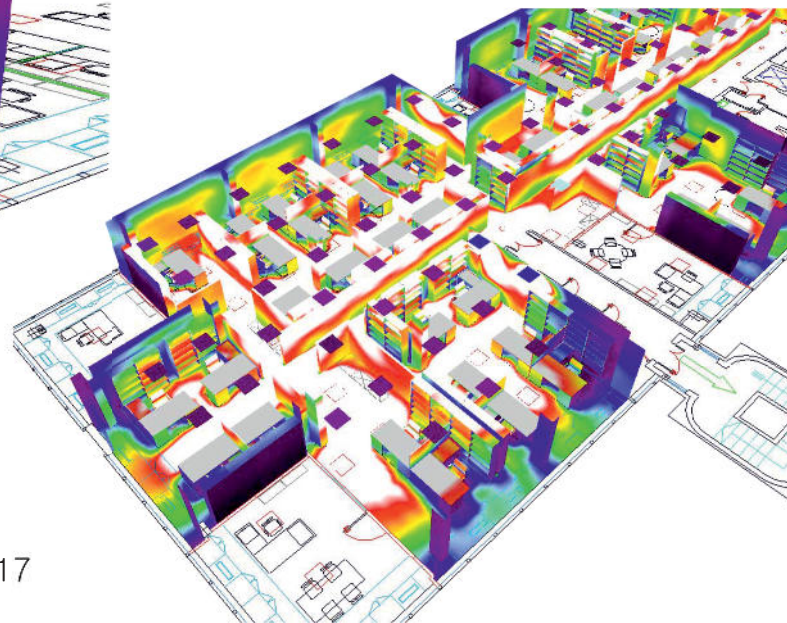
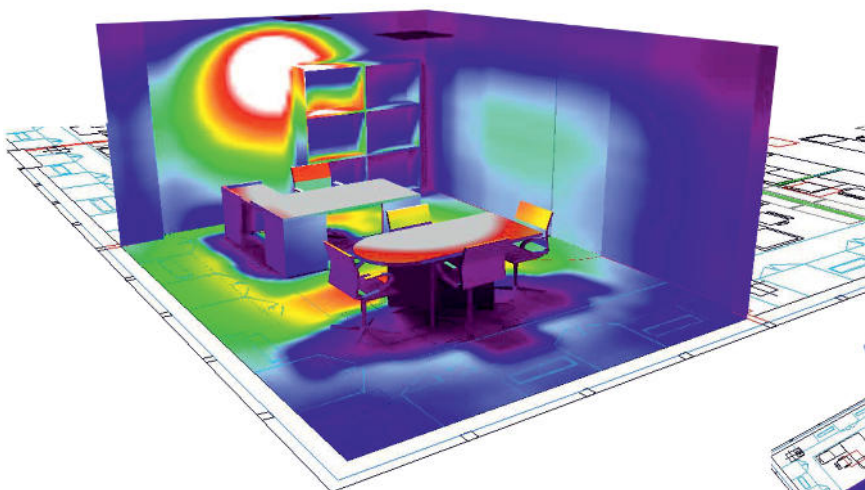

LINEA GUIDA ILLUMINAZIONE DI EMERGENZA

AMBIENTE

- Luoghi di lavoro



HACCP

- Abitazioni



- Edifici civili



- Attività alberghiere



HACCP

- Attività commerciali



HACCP

- Pubblico spettacolo



HACCP

- Edifici scolastici



HACCP

- Asili nido



HACCP

NORMATIVE

- D.Lgs 81/08
- D.Lgs 106/09
- DM 10/03/1998
- UNI EN 1838

- CEI 64-8 art.37

- DM 16/05/1987
- CEI 64-50

- DM 09/04/1994
- CEI 64-50

- DM 27/07/2010

- DM 19/08/1996
- CEI 64-8

- DM 26/08/1992
- CEI 64-52
- UNI 10840

- DM 16/07/2014
- UNI EN 1838

PRESTAZIONI RICHIESTE

Le prestazioni in questi ambienti sono dettati da normative e decreti specifici. Dove non vi è nessun riferimento a riguardo si segue la UNI EN 1838

- **Illuminamento** 1 lux a terra
- **Autonomia** 1 ora
- **Tempo di ricarica** 24 ore

Negli appartamenti il numero di lampade di emergenza è stabilito dai metri quadri della superficie e dal livello dell'impianto elettrico

Superficie	Livello 1	Livello 2	Livello 3
<100m ²	1	2	3
>100m ²	2	3	3

L'illuminazione è obbligatoria negli edifici con altezza antincendi superiore ai 32 metri.

- **Illuminamento** 5 lux ad 1m da terra lungo le scale e a ridosso delle porte; 2 lux negli altri ambienti

L'illuminazione deve essere prevista lungo le vie di esodo, nei locali pubblici e quelli frequentati dal personale. Per le strutture con meno di 25 stanze le prestazioni sono le stesse dei "Luoghi di lavoro", mentre per quelle con più di 25 stanze è indicato seguire i seguenti dati:

- **Illuminamento** 5 lux ad 1 metro da terra
- **Autonomia** 1 ora
- **Tempo di ricarica** 12 ore

Per i locali commerciali con superficie superiore ai 400m² le normative indicano:

- **Illuminamento** 10 lux ad 1m da terra lungo le vie di esodo e 5 lux negli altri ambienti frequentati dal pubblico
- **Autonomia** 1 ora e 30 minuti
- **Tempo di ricarica** 12 ore

Per i locali dedicati al pubblico spettacolo si seguono le indicazioni seguenti:

- **Illuminamento** 5 lux ad 1 m da terra lungo le vie di esodo e 2 lux negli altri ambienti frequentati dal pubblico
- **Autonomia** 1 ora
- **Tempo di ricarica** 12 ore

Per le strutture scolastiche è richiesta un'illuminazione di emergenza specifica

- **Illuminamento** 5 lux minimi ad 1 m da terra lungo le vie di esodo, nelle aule, nelle aule magne e nelle palestre
- **Autonomia** 30 minuti
- **Tempo di ricarica** 12 ore

In tutti gli ambienti negli asili nido deve essere presente un'adeguata illuminazione di sicurezza:

- **Illuminamento** 1 lux lungo le vie di esodo e 0,5 lux nelle aree antipanico
- **Autonomia** 1 ora
- **Tempo di ricarica** 24 ore

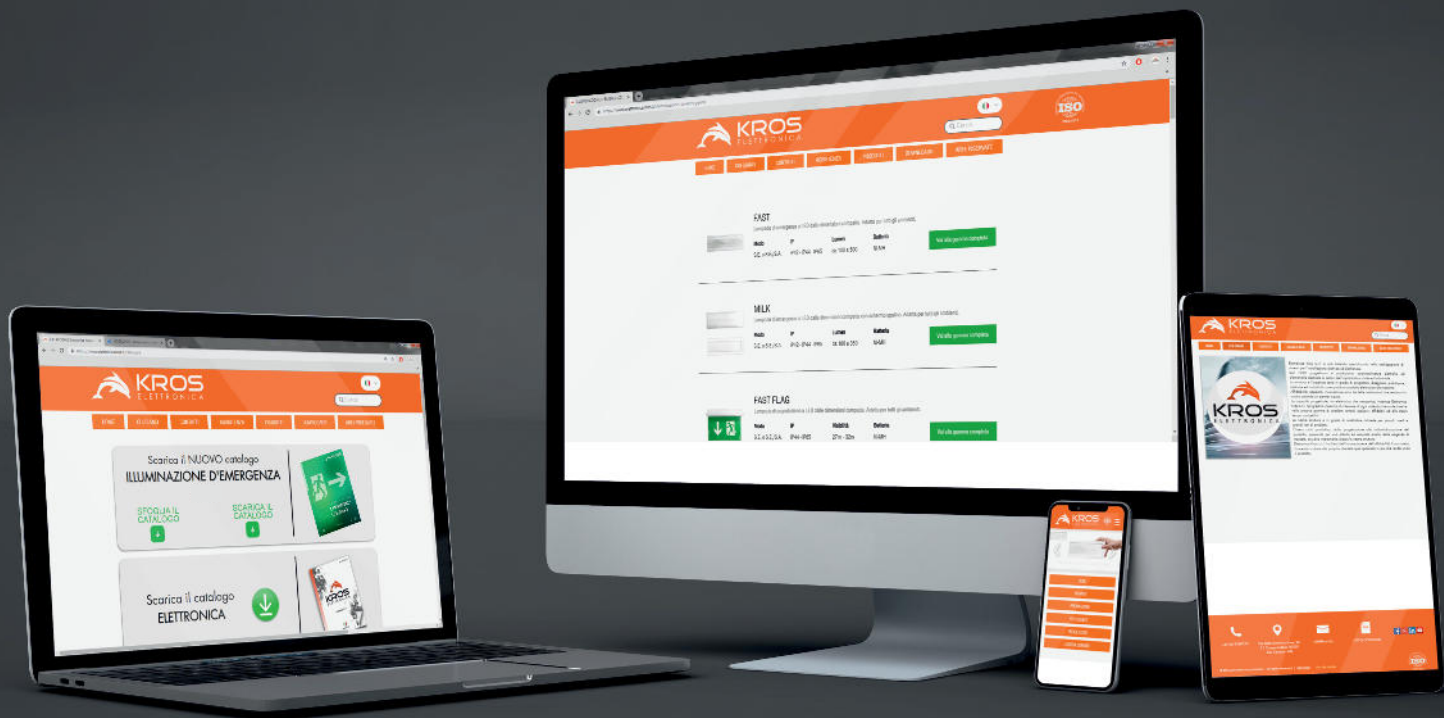

www.elettronicakros.it

Necessiti di documentazione tecnica e non la trovi nel sito?
 Contattaci all' e-mail ufficiotecnico@elettronicakros.it, ti
 risponderemo in breve tempo.



Dove siamo

SITUATI A 10 MINUTI DAL G.R.A.

Via della Comunicazione, 2 - 00030 San Cesareo (RM)

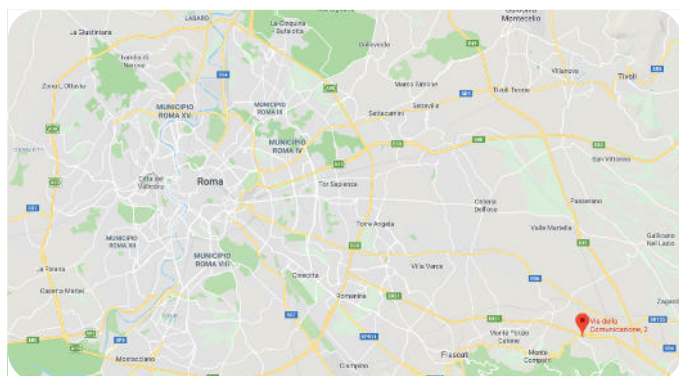

ASSISTENZA WHATSAPP
+39 3471931232

Supporto clienti

Dal lunedì al venerdì - 8:30/13:00 - 14:00/17:30

RICHIESTE GENERALI



+39 06 9588359



info@elettronicakros.it

COMMERCIALE



+39 347 1931232



oem@elettronicakros.it

ASSISTENZA TECNICA



+39 06 9588359



assistenza@elettronicakros.it

PROGETTI ILLUMINOTECNICI e CERTIFICAZIONI



+39 06 95595017



ufficiotecnico@elettronicakros.it

QUALITY MAKES THE DIFFERENCE



ELETTRONICA KROS S.R.L.
Via della comunicazione, 2b - 00030 - San Cesareo (RM)
Tel. +39 06 9588359
Fax +39 06 95599454
Email: info@elettronicakros.it
web: www.elettronicakros.it

www.elettronicakros.it



contact us:



MADE IN ITALY

